

TABLE OF CONTENTS

1.	INTERPRETATION	3
2.	AUTHORITY TO EXCLUDE	3
3.	GENERAL	4
4.	CONSTRUCTION	4
	GLOSSARY OF TERMS & DEFINITIONS	4
5.	DECLARATION OF COMPLIANCE	5
6.	REGISTRATION	5
7.	MEASURING OF CARS	5
	Fig 1: Wheelbase Calculator	6
8.	PENALTIES	7
9.	DRIVER SAFETY	7
	PROTECTIVE CLOTHING	7
	Helmet	7
	Seat Belt	8
	Fig 2.(i & ii) Restraints	8
	Fig.3 (i – iv) Restraint System	9
	INSTALLATION OF DRIVER RESTRAINT SYSTEMS	9
	ADJUSTMENT OF DRIVER RESTRAINTS	10
	WINDOW NET	11
	Fig 4 Window Net	11
	Fig 4 (i)	12
	Padding	12
	Fire Extinguisher	12
10	SEAT	12
	Fig 5 Typical Seat	13
CLASS SPECIFICATIONS		
11	BODY/ROLLING SHELL	14
	Fig 6 Engine Position	14
	Fig 7 Wheel Arch Modification	16
	Fig 8 Triangular Roof Plate	17
	Fig 9 Front Barwork	18
	Fig 9 (i) – (ii) Front Barwork	18
12	NON ORIGINAL BODY FIREWALL	19
13	ROLL CAGE	19
	Fig 10 (i) Typical Roll Cage	20
	Fig 10 (ii) – (iii) Cage Details	22
	Fig 10 (iv) – (v) Cage Details	23
13	BALLAST	23
14	HEAD PLATE	24
	Fig 11 Head Plate	24
	Fig 11 (i) Raised Head	24

15	TRACK.....	25
16	WHEELBASE.....	25
	Fig 12 Track & Rim Measurement.....	25
17	BUMPER Bars & OPTIONAL EXTERNAL BARWORK.....	25
	Fig 13 Bumper and Stay Bars.....	26
	Fig 14 Rub Strip Mounting.....	27
	Fig 14 (i) Rub Rails.....	27
	Fig 15 Front & Rear Overrider Bars.....	28
18	ENGINE.....	29
18.1	EFI ENGINE.....	30
18.2	EFI ENGINE.....	31
19	BATTERY AND ELECTRICAL SYSTEM.....	32
	Fig 16 Battery Clamp.....	32
20	EXHAUST SYSTEM.....	33
	Fig 17 Internal Exhaust Duct Body Vent.....	33
21	COOLING SYSTEM.....	33
22	TRANSMISSION.....	34
23	STEERING.....	35
24	SUSPENSION.....	35
25	WHEELS.....	36
26	TYRES.....	37
27	BRAKES.....	37
28	FUEL.....	38
29	FUEL TANK AND FUEL SYSTEM.....	38
	Fig 18 Fuel Tank Protector.....	39
	TABLE 2 Engine for Model.....	40
	TABLE 2 EFI Engine.....	40
	TABLE 2 EFI Valve sizes.....	40
	TABLE 3 Dimensions.....	41
	TABLE 4 Tyre Ratings.....	42
	TABLE 5 Throttle Body.....	42

PLEASE NOTE: Where possible the data in the Specification Manual has been taken from the Glass's Directories, which is the main reference book used by the SSA Inc. Information that is not available in the Glass's Directories, is taken from Manufactures Workshop Manuals. We have checked and cross checked the information in this Manual. If you do find something that does not seem to be right, anywhere in this Specification Manual, please let us know immediately, so that we can check it out and if it is wrong, we can change it.

© **All rights reserved. Reproduction or translation of this Manual, in whole or part is not permitted without written authorization from Speedway Sedans Australia Inc.**

SPEEDWAY SEDANS AUSTRALIA Inc. SPECIFICATIONS

INTRODUCTION

1. INTERPRETATION:

The Speedway Sedans Australia Inc. (SSA Inc.) shall direct the enforcement of these specifications in all aspects.

SSA Technical Committee shall be the sole authority for the interpretation of the specifications as contained in this book and any circularised amendments.

AMENDMENTS to this Manual may be made during the life of this Manual for the reasons as set down in SSA Inc. Policy governing such amendments. The amendments will be approved by the SSA Inc. Board and circularized to all Clubs and competitors by way of a Media Release and/or in Tek Torque. A stick-in advising this amendment will be provided in the front of all Manuals purchased after the amendment becomes law. Amendments circularized in such manner, shall be deemed to be as valid as the contents of this manual and must be adhered to by all Competitors and Scrutineers.

Specific decisions made by Federal/State/Zone Officers shall be subject to ratification by the Federal Technical Committee, after due notice of the decision and reasons have been given. All enquiries must be directed to your local Club Scrutineer.

SSA Inc. cars must only race with SSA Inc. Registered cars, with SSA/NASR Licenced drivers with SSA Inc. approved Insurance

2. AUTHORITY TO EXCLUDE:

If a SSA Inc Official determines prior to the race that the Race Car does not meet the applicable specifications, the car will not be allowed to compete unless, in the discretion of the official, the deficiency:-

- a. will not adversely affect the orderly conduct of the race.
- b. will not provide the competitor with a significant competitive advantage over other competitors.
- c. is so insubstantial as not to warrant a determination that the car is ineligible to race.

If the Official permits the car to compete under these circumstances, the Official will advise the competitor in writing of the deficiency, and if the deficiency has not been corrected within the allotted timeframe, the car will be prohibited from competing in any future event.

3. GENERAL

Specifications listed in this book are a guide to building race cars unless otherwise stated. If "IT" is not in the book, then it cannot be used.

Before constructing cars of unusual or unconventional design, full details are to be submitted in writing to the SSA Inc Technical Committee via Club and State Secretary. If requested, this submission shall be handled "CONFIDENTIAL", and approval or required modification before approval shall be given in writing to the applicant. A fee applies.

4. CONSTRUCTION:

Workmanship on race cars is to be of a professional standard.

All materials used must be of good quality.

Bolts are not to be used through structural tubing in the rollcage cabin area unless a welded sleeve is provided.

No tek screws or self tappers to be used.

No pop rivets in roll cage tubing.

All material sizes quoted are minimum unless a maximum is stated.

TRANSPONDERS are to be mounted no more than 450mm forward of the front axle centreline.

Reshelling of a currently registered race car is permitted if same make and model and no fee is payable.

One Way Communicators are mandatory for all race meetings.

GLOSSARY OF TERMS & DEFINITIONS:

Material:

CHS - Circular Hollow Section.

RHS - Rectangular Hollow Section.

W.T. - Wall thickness.

AS1163 Gr300 - Australian Standard 1163 for structural steel tubing Grade 300

FMS - Flat Mild Steel

O.D. - Outer Diameter

OEM - Original Equipment Manufacture; used to indicate parts used, or the complete vehicle as it left the production line from the original manufacturer and means for make and model unless otherwise stated.

CARBURETTOR - Is to have all working parts in use, e.g. needle and seat, fuel bowl, float, jets etc and fuel is to be naturally delivered to the main jet by atmospheric pressure. The air pressure in the carburetor venturi being lower than atmospheric pressure, allows fuel then to flow from the bowl to the carburetor venturi as the pressure in the carburetor throat decreases.

Fuel is then drawn down the venturi and carburetor throat by vacuum provided by the rotation of the engine.

Carburetors that are of different configuration than that of the above must be submitted to the Federal Technical Committee for permission to use. A complete description must accompany the submission to substantiate your request.

5. DECLARATION OF COMPLIANCE:

The PERSON RESPONSIBLE for the LEGALITY of the car, will complete a SSA Inc DECLARATION OF COMPLIANCE ANNUALLY.

Declaration will cover ELIGIBILITY for class and ALL points of SAFETY including material specification and sizes. Details of the declaration are to be placed in the log book.

REGISTRATION IS NOT COMPLETE UNTIL Pages 3 to 6 of the LOG BOOK are completed and signed by both the Owner/Driver AND the Scrutineer/Machine Examiner or Registrar.

Structural or other specification changes made during the year MUST be notified to the respective Officials and adjustments will be made to the Log Book if required.

The Driver must have a SSA/NASR licence and a SSA Inc. Infringement Card.

6. REGISTRATION:

A SSA Inc new registration can only be issued for a race car, provided that the car conforms to the SSA Inc. Specification Book for the Class in which the car is to be registered.

The car must pass an annual registration examination and a registration decal will be issued and must be attached to a prominent location on the car. A car being re-registered must have the log book from the immediate previous season otherwise the chassis area and roll cage will be subject to new car specifications.

A complete metal body shell including roll cage is the basis for the registration of a race car.

The DRIVER is responsible for having the log book further endorsed before participation in each official practice session or race meeting.

A log book without endorsement by the Machine Examiner is equivalent to a no-race ticket.

7. MEASURING OF CARS:

All cars are subject to engine and general measurement at any time by a Scrutineer, State or Federal Technical Committee OR at the direction of the Federal Technical Advisor, or the Federal Technical Committee, or the Steward or the Racing Disputes Committee.

The SSA Inc. reserves the right to impound and inspect any race car at any time. Cars can be selected and ordered to the impounded area for dismantling. This may include removal of any seals for inspection and if found non compliant, registration

may be revoked. The entrants of the cars must deliver them immediately upon request and supply the necessary manpower and hand tools to accomplish dismantling.

Only persons actually involved in dismantling the car will be allowed in the immediate area of a vehicle being checked. Persons associated with other cars being checked are to remain with their own car.

Any persons not having cars in the impound area and gaining entry without authorisation, will be ejected.

If there are no facilities for ready check of any parts of a vehicle, sealing of parts under question can be carried out and vehicle taken to a mutually agreed venue for examination at another time, but within fourteen (14) days.

Impounded cars will be stored at the owner's risk. Although every reasonable precaution will be taken, no responsibility for fire, theft or damage will be assumed by the SSA Inc. and/or affiliated clubs or members.

Fig.1.

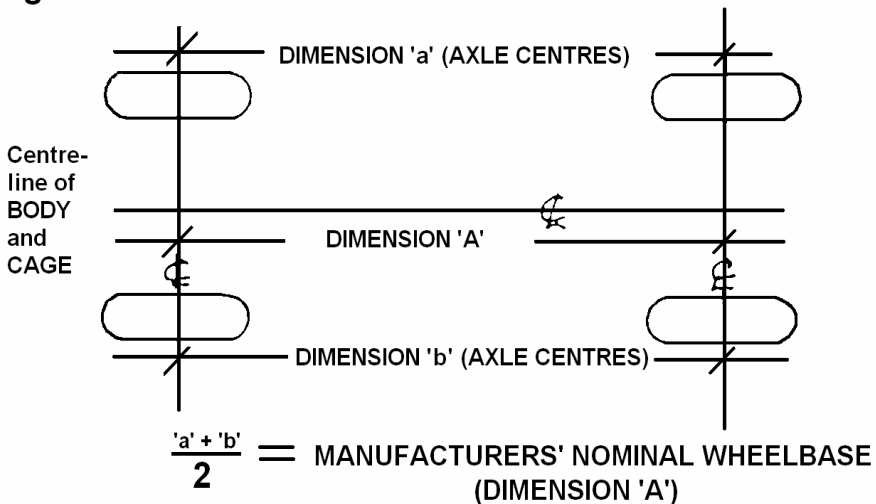

Method of measuring wheelbase shall be:- With each front wheel pointing straight ahead, measure distance from front axle centre to rear axle centre on each side of vehicle. Add dimensions for left and right, divide by 2. Allowable tolerance +/- 1%.

All engines are to be sealed to enter events.

8. PENALTIES:

This Manual must be read in conjunction with the Australian Speedway Racing Rules and Regulations and/or notices issued by the SSA Inc. from time to time. Ignorance of these Regulations and Specifications and notices shall be deemed as no defense in regard to breaches and/or appeals of same.

9. DRIVER SAFETY:

All protective clothing and safety equipment must be used and/or worn in the approved and accepted manner whilst competing, or testing and/or practice.

All racewear/equipment to be inspected at each practice/race meeting.

PROTECTIVE CLOTHING:

The following are minimum safety standards:-

RACE SUIT: Minimum standard of either SFI 3.2A/1 or the higher standard of apparel, a snug fit at ankles, collar and cuffs, and must be fully fastened at all times whilst in the car.

UNDERWEAR: Comply with SFI 3.3, FIA 8856-2000 and must be worn. Drivers must only wear cotton socks and under-garments eg. No synthetic boxer shorts, and no under wires on bras. No synthetic attire and no jewellery to be worn by a competitor whilst completing.

BALACLAVAS: Comply with SFI 3.3 or FIA 8856-2000 and must be worn

BOOTS: Comply with SFI 3.3 or FIA 8856-2000

GLOVES: Comply with SFI 3.3 or FIA 8856-2000 and must NOT be modified in any way.

HELMET: Full faced and comply with the AS1698 standard and must be no older than 5 years from the manufacturer date. The higher Snell standard helmet can be used and is recommended. However, if helmet is misused, neglected, or damaged, it may be rejected and impounded by Machine Examiner or Technical Committee at any time, and if considered to be unsafe, scrutineers log book entry to be completed along with drivers log book and helmet cannot be used again for any speedway event. Chin cup on helmet not permitted. Spectacles, visor or sunglasses, when worn, must have lenses of non-splinterable material.

HORSE COLLAR: Compulsory if driver is not using a Head and Neck Restraint.

HEAD AND NECK RESTRAINT: Recommended but not mandatory, If worn a Head and Neck Restraint must conform with SFI 38.1. An AS1698 helmet must not be modified in any way. Only a SNELL SA-2005 or Snell SA-2010 helmet can be modified to wear a head and neck restraint device.

SEAT BELT: Five or six mounting point restraints are mandatory. Shoulder and Hip Belt width 50mm minimum. 75mm highly recommended.

SEAT BELT LIFE:- MAXIMUM OF FIVE YEARS FROM DATE OF MANUFACTURE
Only belts with over centre lever lock buckle to be used.

An approved type racing harness must be fitted, using a minimum of four major belts and four mounting points, plus one or two anti-submarine/crotch straps. Anchor bolts to be 10mm steel min.

Shoulder belts to have separate anchor points/adjusters. Fig 2 (i)

Shoulder belt mounting points shall be positioned to the rear and below the point at which the shoulder belts come through the seat and be not more than 300mm from that point, attached to 38mm x 3mm tube. Fig 2 (ii)

Lower seat belt mounting brackets (anchor points) must be on roll cage and chassis or substantial barwork using a minimum construction of 25x25x3mm RHS or 25mm OD CHS.

Seat belt attachment tag to be 3mm minimum mild steel.

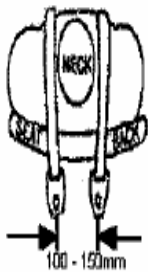

Fig 2 (i)

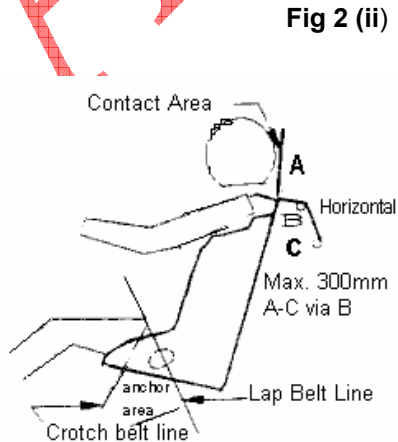
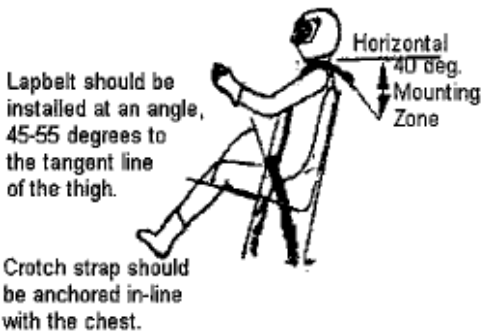

Fig 2 (ii)



Seat belts should be anchored apart the same distance as the driver is wide. Mounting brackets should be angled the same direction as belts pull and not tilted in or out.



Fig. 3

Shoulder harness should be anchored at a 45 degree angle from the seat. If mounted to a roll bar cross brace, located 100mm below the shoulder line.

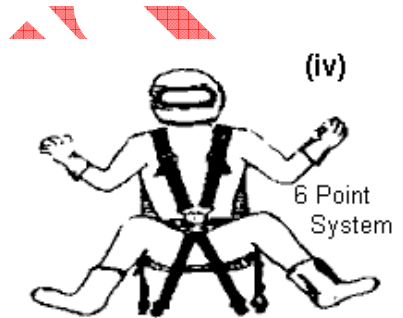

Crotch strap mounts as far apart as comfortable.

Fig 3 Simple Seat only shown for clarity. See "Installation of Restraint System". See "Adjustment of Driver Restraints".

Lower seat belt mounting brackets (anchor points) must be on roll cage and chassis or substantial bar work using a minimum construction of 25x25x3mm RHS or 25mm OD CHS. Seat belt attachment tag to be 3mm minimum mild steel.

INSTALLATION OF DRIVER RESTRAINT SYSTEMS: Fig 3

In order for the driver restraint system to be fully effective, considerable thought must be given to the location of mounting points, and to proper installation.

With the seat, roll cage and belt anchors all part of the same structure, deformation of the remainder of the car does not put driver at serious risk.

The mounting points must be solid and should remain so even if the vehicle is deformed due to an accident. The mounting points should also not put undue strain or twist on the belt system hardware.

The lap belt should be positioned so it rides across the solid pelvic area and not the soft stomach area or down on the thighs. The shock absorbing ability of the pelvic

area and its ability to protect internal organs make it the preferred location for the lap belt. See Fig 3 (i) & (iii).

The shoulder harness should be mounted to prevent driver's shoulders from moving forward (upward if semi-reclining), out of the seat, in the event of a rollover.

The required minimum 50mm from the top of the driver's helmet to the roll cage roof & head plate/hoop bar. Anti-submarine straps serve two purposes.

1. To secure the lap strap down across the driver's hips, so in the event of an accident, it is not pulled up across the stomach by the shoulder straps.
2. To prevent the driver from sliding forward and out of the harness. When the driver is seated in an upright position, as in most sedans, a five point system (a single anti-submarine or crotch strap) is considered adequate Fig 3(ii). For extra assurance a double strap anti-submarine belt can be used Fig 3(iv).

When the driver is seated in a semi-reclining position a six point system (two anti-submarine or crotch straps) is preferable. Most drivers find the two anti-submarine strap system more comfortable.

In many instances, the anti-submarine straps are mounted much too far forward of the seat. This practice could cause unnecessary injury as the body can slide partially out of the seat before being restrained when the strap contacts the groin. It is much more practical to cut a slot in the seat bottom so the anti-submarine strap can be anchored in line with the chest. Fig 3 (i)

Because of the differences (often vast) in competition vehicles, a 'standard' method of mounting is impractical. Good judgement and common sense in inspecting restraint system mounts is needed.

Safety equipment is often neglected in favour of performance equipment, but its proper operation when the need arises is essential to survival.

ADJUSTMENT OF DRIVER RESTRAINTS:

With the driver fully kitted out in 'long johns and driving suit', check that, with the driver seated, belt slots in the seat line up with natural line of the belt from anchor to buckle when just the lap belt is tensioned. Ensure that the lap adjusters do not foul the seat and that they are readily accessible. Some belts adjust by pressure downward others by pull up.

Check that the driver can manipulate belt adjusters with gloves ON. Check also that anchor hardware is aligned and that it is not possible to have a hitch in the anchor area without detection (sudden release of the belts to 50mm slack can put the driver off-line). Now check if the belt is holding the seat or the driver, it should be the latter.

Adjust the anti-submarine strap/s to ensure that the buckle is held flat and close to the body over the pelvis. When satisfied that the lap belt is OK, put on the helmet and check just how far the helmet (with visor) can reach, head plate clearance, helmet net etc.

Slacken the seat belt, engage the shoulder belts into the buckle and tension the seat belts again, checking position of the buckle and adjusters. Tension each shoulder belt, checking that the adjustment range is suitable to the driver, that the belts and hardware don't foul the seat and that the natural line of the belts hold the driver as with the lap belts.

Note also any change in the buckle location and lay. If there is too much variation with the buckle it would appear that lap anchors are not in optimum position.

Before drivers releases the buckle he should slacken shoulder belts with the adjusters, keeping the area of the adjuster supple, accessible for cleaning and making entry to the car a simple routine.

While lining up for restarts, it becomes a simple exercise to tug the adjusters to snug up the belts and stay in control of the car.

WINDOW NET:

Window net is mandatory.

Net to be a minimum 19mm woven webbing with 75mm max hole size. (Fig 4)

Window net minimum rod thickness $\frac{1}{4}$ " (6mm)

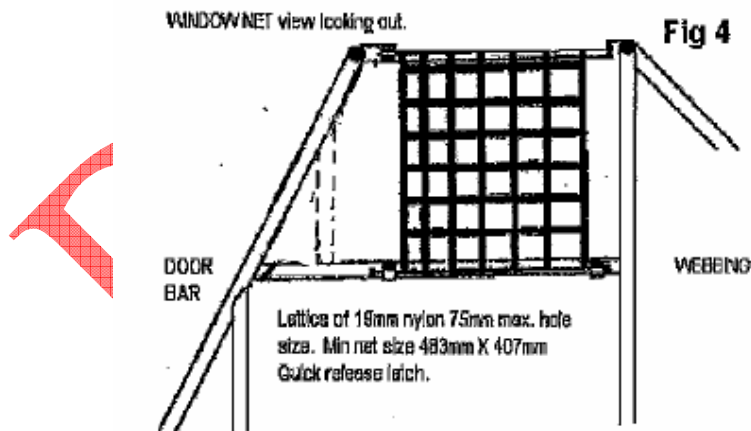

It is recommended that the window net be hinged from the bottom.

Window net must be mounted directly to the roll cage bar (top) and NASCAR bar (bottom).

Window net – lattice of 19mm woven webbing.

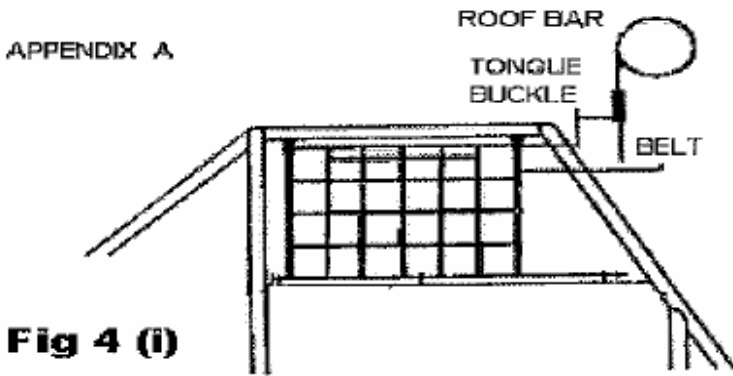

This design uses two push button seat belt buckles and belts. Tongues are welded to side of roof bar. 25 x 3mm FMS welded to rear of buckles. Tubing at base of net fixed with bonnet lock pins.

PADDING:

The driver must be protected in the race car, from all sharp edges and projections or bar work which could cause injury in an accident.

FIRE EXTINGUISHER:

On board fire extinguisher permitted. It must be securely mounted and be of the correct type for the fuel being used.

10. SEAT:

Minimum 50mm clearance helmet to the roll cage roof & head plate/hoop bar.

- a. Seat to be mounted totally on the right hand side of the vehicle centreline measured at waist line of body.
 - (i) 4 DOOR CARS. No part of the seat may be more than 125mm behind the centre pillar.
 - (ii) 2 DOOR CARS. Must not be further back than rear of "B" pillar, both measured at window sill height

Seat base to be mounted to roll cage chassis at a minimum of two points using 8mm bolts and minimum of 40mm diameter body washers. Four points recommended.

Seat back to be braced to, and attached to, the roll cage approx 75mm below shoulder height using a minimum of two 8mm bolts and 40mm body washers.

- b. A "Purpose Built" one piece, solid (i.e. no lightening holes), steel, aluminum, or fibreglass bucket type seat incorporating a substantial head rest must be used. Plastic seats are not permitted. Minimum thickness of aluminum and steel seats is 3mm. The minimum thickness of a fibreglass seat is 5mm. Approved proprietary line competition seats and mounts permitted E.g. Kirkey/Butler/Genesis/United Speedway Accessories/Bratpack Racetech New Zealand Composite seat.

Spring upholstered or magnesium alloy seats not permitted.

Recommend full containment seat or at least head and shoulder support.

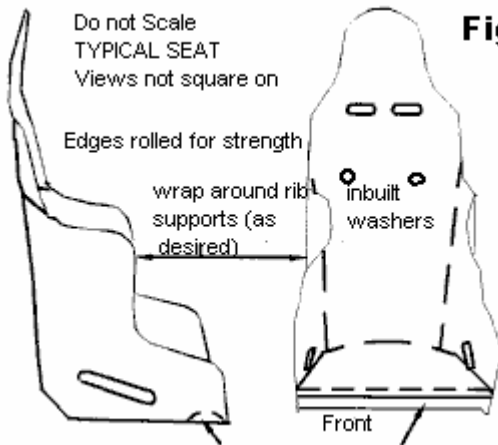

- c. Lateral (sideways) support must be given to hips and above waist. Concave seat to support back to minimum of TOP of shoulder height and width. Top of head rest to be at least 50mm above helmet contact point. Head rest must be padded. At the discretion of the Scrutineer the head rest will need a form of support, if it is deemed too flexible and/or the area between seat and rollcage is too great. Upper support (mounting bolts) should not exceed 75mm below shoulder height. Cut-outs for belts to be suitably grommetted and have adequate clearance. All seats may be padded and covered, the covering being securely attached. Maximum padding thickness 50mm.

PRODUCTION SPECIFICATION

A Production class race car is built from a hard-top road car seating a minimum of four persons, as per the compliance plate, and catalogued for sale in Australia, i.e. available new, to the general public, through authorised Dealer sales and service networks throughout Australia.

"Base model" body is used for silhouette, measurements and specifications. If unsure of base model options refer to Glasses Dealers Guide or a car park check if required. Forced induction models not permitted in that form.

Four wheel/all wheel drive and/or four wheel steer models not permitted.

Passengers optional as per state ruling.

Age limit on Production eligibility – 5 years. For 2011 - competitor can only build up to 2006 model car.

11. BODY/ROLLING SHELL:

EARLY MODEL ENGINES – LATE MODEL BODIES BE PERMITTED

202 inline six cylinder fitment to VT, VX, VY, VZ Commodores and Monaros.

675mm (26 ½ ") from rear face of engine block to K-frame bolt on chassis rail.

Engine to be mounted with rear face of engine block in the original position.

"Engine offset is not permitted."

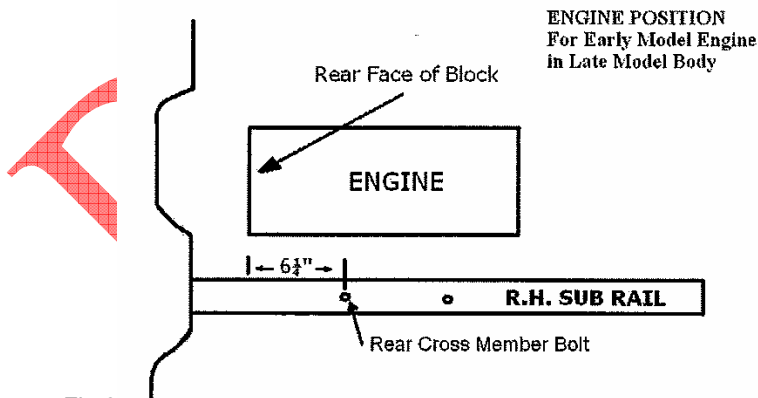

Fig 6

- Race car is to use an original, complete, metal body with the suspension mounting points in original position and being used, including complete original steel front firewall. (E.g. Commodore VN upwards must use OEM firewall.)
- Cars may be upgraded by using later panels in same series (i.e. VN - VS Commodore or EA - EL Falcon).

The updated panel must be attached over the complete original panel, but must be registered as the original model.

N.B. Cars after this series (VS Commodore & EL Falcon) cannot upgrade their panels.

- c) All fittings such as door handles, visors, ornamental mouldings, body trim strips; wheel trims etc. must be removed.
- d) All unnecessary flammable material must be removed, e.g. door trims, floor coverings; attached sound deadening material permitted except near exhaust system.
- e) All window glass and lights must be removed. (Window Glass apertures must not be covered with fibreglass or other material)
- f) Instrument glass permitted.
- g) The only panels which may be replaced with fibreglass/ metal/aluminium replica: - max 2mm thick, are doors, bonnet, boot, front guards and nose.
If the original roof has been damaged you may fit a fibreglass roof skin overlay on (mono cars), only if the original roof remains intact.
Under panel reinforcement plate not permitted.
- h) Replacement panels must be securely fastened; self drilling (TEK) screws are not to be used. Panels to be attached using rivets or bolts. No cable ties or race tape unless race night repairs.
- i) The only panels which may be removed: Radiator support panel, front inner guard panels (provided that they do not constitute suspension mounting points e.g. McPherson strut), rear quarter panels and all inner panels in the boot area. Quarter panels to be cut off at rear window base line. Rear silhouette to be maintained with plastic OEM bumper over top of pipe bar work, the door pillars (may be notched for barwork but otherwise must remain intact and in the original position), roof inner panels (ONLY at the points where interference with the rollage occurs), dash panel, boot inner panels, boot floor and/or rear wheel arch sections rearward of the rear axle centre-line (provided that they do not constitute suspension mounting points).
- j) Modifications to rear firewall, front firewall, rear parcel shelf, floor and engine tunnel not permitted unless otherwise specified within this manual. No extra decking or internal sheeting permitted in the cabin.
- k) If rear wheel arches need to be enlarged for tyre clearance, the original wheel arch maybe split and an insert fitted, and the remainder of inner and outer arch panels must be re-welded. Fig 7.
Inner front wheel arches and fender skirts where they attach to the sub frame and floor area may be re-positioned for wheel clearance max 50mm.
- l) Original front sub-frames must remain in place, except that; the sections forward of the leading edge of both front tyres may be removed, unless they constitute suspension mounting points; e.g. forward caster arm (radius rod) mounting on McPherson strut.
Front wheel drive cars with transverse engine may modify the engine cradle assembly to strengthen the engine mount.

- m) Front and rear under bumper stone trays;
 - 1) front must be original in shape.
 - 2) rear must be of original shape and material.

Fig 7 Wheel Arch Modification

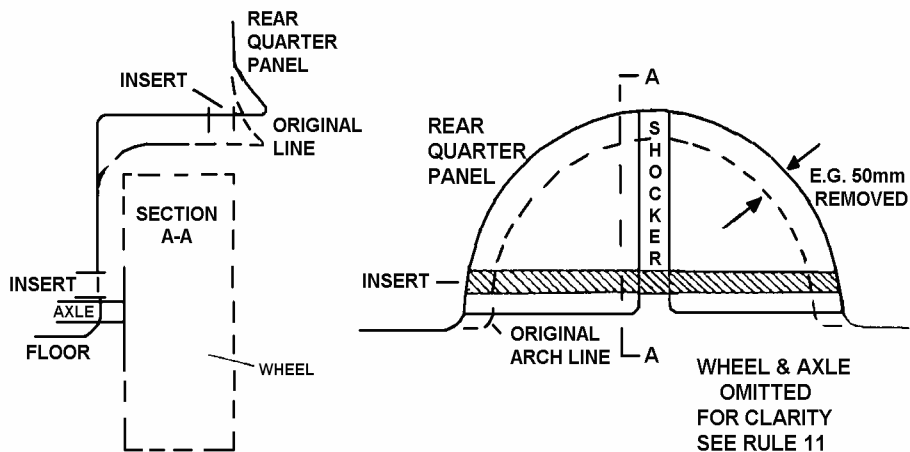

- n) Rear SPOILER and/or front air dam permitted if manufacturer's option for the model. Aerofoil permitted if OEM standard fitment for base model. V8 Super Car type, Walkinshaw and similar derivatives not acceptable or permitted on rear.
 Spoiler or Aerofoil fitment not permitted to be above half rear window height, not wider than waistline of the car at that point nor further to the rear than the back of an original rear bumper.
 Other aerodynamic aids NOT permitted.
- o) All Bodywork, including any subsequent repair of race day damage, shall be to a Tradesman-like standard and must permit the vehicle to be presented in as near to original condition as possible.
- p) Paintwork and Sign Writing: All paintwork, sign writing and numbers to be neat, attractive and of a professional standard. All vehicles must carry the identification number, as issued by their club. This number may be displayed on each side of car and on the roof.
 Club prefix, if required, to precede number. Identification number to be visible from front of car (for Pit Marshall).
 The name of the driver will appear on the roof over RH door or on visor strip, in letters of a minimum of 75mm high.
Roof Plate: The use of a roof plate number is mandatory for all race meetings, State and National titles. It shall be a metal plate, 30cm square with a 5 cm right angle fold at the bottom, where 2 holes, at 20cm centres shall be drilled to

take 6mm bolts. The number on the plate shall be painted using a black background & white number/s. Number to be minimum 250mm high in block font.

A triangular 3 sided roof number is OPTIONAL. Plate to be 300mm x 300mm x 300mm. Black background with white number. Fig 8.

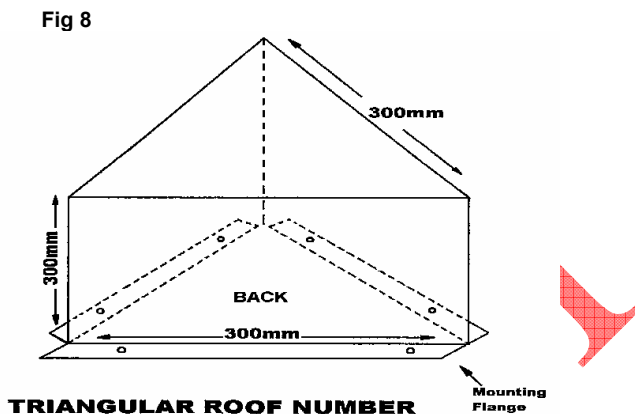

- q) Fuel Tap lever or switch to be marked, indicating FUEL and the positions ON/OFF.
Kill Switch to be clearly marked, in contrast colour, for method of operation e.g. DOWN/OFF.
- r) Except for the bumper and bumper support bars, all bar work outside the sub-frame skirts forward of the firewall, i.e. under front guards, shall be a maximum outside dimension of 25mm and a maximum wall thickness of 3.2mm Fig. 9(i) (ii) (iii). Max 3 braces per side, one may be a vertical upright attached to the bumper support. No other bar work to attach to bumper bars or supports.
Any mud protectors under car, to be not lower than 150mm above ground.
- s) Bonnet to be securely fastened. Four bonnet pins (5 for fibreglass) to be 12mm min. to 15 mm max. mild steel, or approved equivalent.
Bonnet pins are to be in the bonnet, not sides of mudguards. No mounting pins in side of panels, i.e. mud guards.
Bonnet lock pins 3mm min to 6mm max. Heavy duty large reinforcing washers (min 30mm O.D.) to be fitted to all bonnets pin holes.
Similarly, boot lid to be securely fitted, using pins and large washers as for bonnet. A removable boot lid to be securely mounted at four points.
Hinged bonnet and boot lid permitted, using minimum of two pins. Skeletonising not permitted on hinged panels within 50mm of hinges.
The hinged panel to be welded to the bonnet or boot skin.

Fig 9

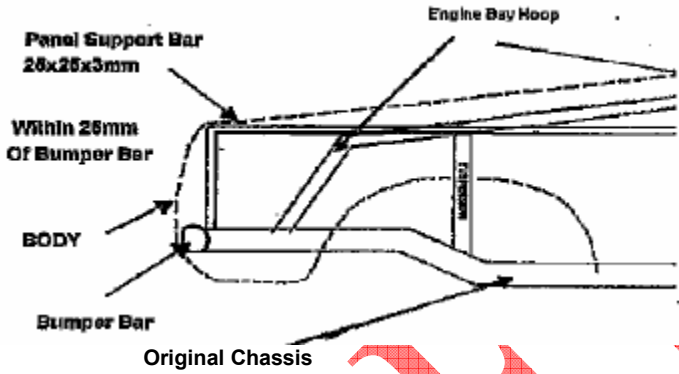

Fig 9 (i)

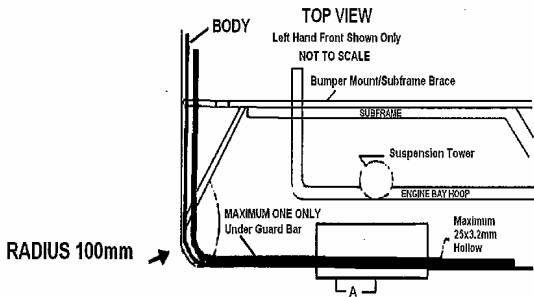
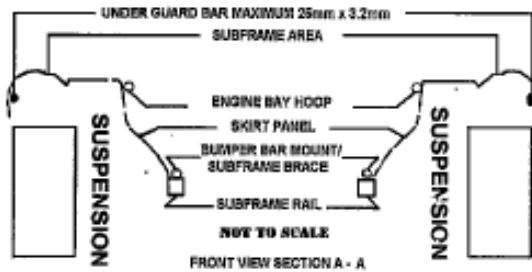

Fig 9 (ii)



- t) Fuel tank area must be accessible for scrutineering, 300mm x 300mm (access panel may be in rear parcel shelf, deck panel or be the boot lid).
- u) Grille may be fabricated, 3mm max. FMS, but is to resemble the original. Multi-piece sheet metal, brittle plastic, or die cast grille and/or fittings not permitted.
- v) Cars may have a wheel arch flare if Manufacturer's OPTION for the model and to be of original type and shape.
Flares to be of body material only.
Flare edges and/or guard edges are not to be reinforced.
- w) Light apertures and grille must be filled using max. 1.6mm metal sheet, fibreglass or plastic, grille to be 5mm woven mesh if air flow is required.
- x) Rear vision mirror not permitted.
- y) Data logging dashes are not permitted.
- z) Dash panel is not to continue past the forward most point of the steering wheel across the width of the car.
- aa) Metal sheeting only in the drivers foot well may be fitted under the drivers feet, which is also covering the front roll cage spreader bar, so drivers feet do not get tangled in the barwork.

12. NON ORIGINAL BODY FIREWALL:

Driver must be protected and isolated from mechanical, fuel, electrical including battery, (marine type plastic or similar box accepted) and exhaust components, by metal firewalls, min. 1mm thick. (See Exhaust also).

13. ROLL CAGE:

- a) The roll cage is to prevent the collapse of cabin area under impact.
Roll cage to enclose the driver, to be full width and full height of the cabin area and will be within 50mm of the inside line of the "B" pillar, measured at the window sill height, parallel to the window sill line.
The roll bars are to constitute a cage type framework, braced fore and aft. The cage must extend from behind driver's seat forward to the windscreen area and incorporate protection for the driver's feet.
- b) All roll bar material must be of good quality mild steel, AS 1163, minimum Gr300. MINIMUM 38mm O.D. x 3.0mm w.t. CHS. (Sonic test at not less than 2.70mm ABSOLUTE).
Aluminium based materials not permitted.
All bends to be made using a pipe bender with the correct size former.
Galvanised tubing or welding over threaded tubing is not permitted in any structural bar work.
Water pipe fittings or malleable fittings are not permitted.
Roll cages built using other than fusion welding techniques will not be accepted.
Gussets on welded joints may be required at daylight inspection of weld quality.

- c) The rear main hoop & main roll cage bars will each be made of one continuous length of tubing with smooth continuous bends and no evidence of crimping, wall failure or significant weakening. Fig. 10(v).

Fig 10(i)
Typical
Roll Cage.

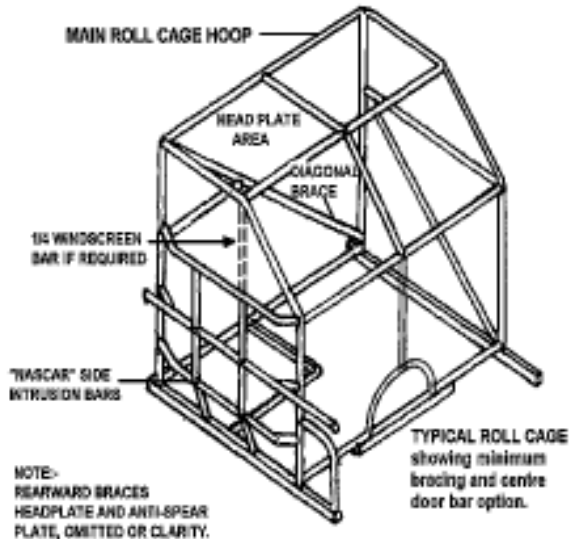

- d) Main rollcage hoop to be within 50mm of sides of roof at narrowest point. Bars are to be inside body. The base of the main roll cage hoop to be fitted square in car.
 Top windscreen bar to be as near as practical to windscreen at front roll cage leg on side elevation.
 Front roll cage leg is to follow the "A" pillar line; exception being cars with severe rake of the windscreen.
 Angle of roll cage "A" pillar bar to be of not less than 45 degrees down from roof bar. Fig. 10(i) 10(ii).
 If a pillar bar does not follow 'A' Pillar line and is 45°, additional subframe cross brace from front of foot protection to LHS may be required.
 Quarter window bar if required because of excessive rake or a long roll cage, to be a minimum of 25mm O.D.
 Roll cage legs shall be welded to the top of a sub-frame of tubular or angle section running fore and aft.

Sub-frame to be securely welded or bolted to the floor pan/sills using at least four 12mm steel bolts through the sub-frame and using 100mm x 100mm plates under the floor.

Sub-frame Material Size:

A. Tubular minimum 38mm x 3.0mm w.t. CHS
or 50mm x 50mm x 3mm w.t. RHS.

B. Angle minimum 50mm x 50mm x 5mm.

- e) A one piece diagonal brace - 38mm O.D. x 3.0mm w.t. CHS., will be fitted in the main roll cage hoop behind the driver's head, (within 250mm. of the bend), top right to bottom left. Fig. 10(iii).

A second brace may be fitted in cruciform.

The diagonal brace, top right to bottom left, must be one piece.

If a cruciform type bracing is used a minimum of 32mm O.D. x 3.0mm w.t. CHS may be used.

- f) **ADDITIONAL MINIMUM BARWORK:**

38mm O.D. x 3.0mm w.t. CHS.

Top windscreen bar. Lower windscreen/dash bar.

Seat back support/shoulder belt mounting bar.

On driver's (Right) side: the centre horizontal door bar may run straight through.

Eg: From front wheel arch to rear wheel arch and then have two separate pieces of 38mm x 3mm turning at 90 degrees to the nascar bar connecting onto the A and B rollcage pillar bars. Door pillar to be notched only, NOT removed, to accommodate bar work.

The top nascar bar, lower windscreen bar and passenger top nascar bar, may be formed in one continuous bar. This entails the A pillar to be formed in 2 pieces. One from the rollcage base to this hoop with the upper section from this hoop upwards to the top hoop.

A minimum of two vertical spacer bars, evenly spaced between front and rear roll cage legs, are to be fitted within each opening from the cage subframe and top nascar bar with a minimum of 6 bars fitted. Fig. 10(i).

Passenger's (Left) side: Two bars between front and rear roll cage legs. One must be horizontal at window sill height.

Minimum of two sub-frame cross braces/spreader bars at roll cage legs, either 38mm O.D. x 3.0mm w.t. CHS or 35mm x 35mm x 3mm w.t. RHS. maximum 200mm from roll cage legs.

Centre roof bar 32mm O.D. x 3.0mm w.t. CHS.

Passengers optional, but all bar work to be mirrored from right hand side.

Passengers must face forward

- g) A quarter window bar, if required because of excessive rake or a long roll cage, be fitted to both sides and installed from the top NASCAR bar to top half of pillar bar using minimum 25x3mm CHS (38mm x 3mm CHS recommended).

Alternately, a 38mm x 3mm O.D. bar may be fitted from top of 'A' pillar bar to top of NASCAR bar at 45° of the top bar on both sides.

Centre windscreen bar, 25mm O.D. X 3.0mm w.t. CHS.

Rearward brace bars from the top rear of main hoop down onto rear sub-frame (approx 45 degrees). May be crucifix.

Must attach to the rearward side of the hoop within 100mm of the centre of the top radius. To be of 34mm CHS.

WINDSCREEN MESH: Mesh screen to cover entire area from "A" pillar to center bar and from dash to roof bar. Maximum effective mesh size 50mm x 50mm. Mesh gauge 3mm. Windscreen mesh to be welded, or clamped with metal clamps to the roll cage "A" pillar and centre windscreen bar. Minimum of four clamps. Mono cars may be welded to body.

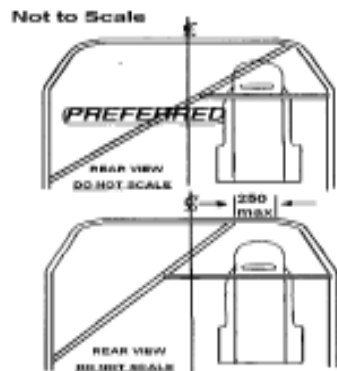
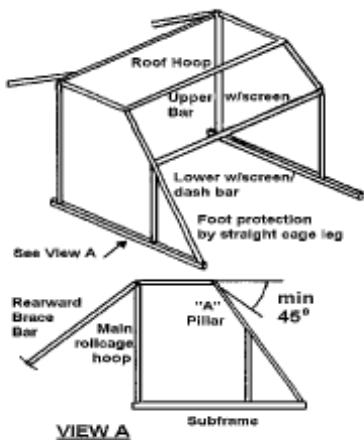

Fig 10 (ii) Cage Details

Fig 10 (iii) Cage Details

- h) One piece anti spear external door plate 3mm steel or 5mm alloy, to be fitted to the outside of the nascar bars. (NOT to be lightened by drilling). Recommended 1/3 length between roll cage legs, to be fitted on drivers side, from floor line to window sill bar, forward of the first vertical door bar, to the front leg of the roll cage: Fig. 10 (iv). If not welded, one piece external door plate to be bolted on, using a minimum of 6 – 50mm x 50mm x 3mm MS tags and bolted to either 8mm or 5/16th high tensile bolts with no protrusions. If individual pieces are used then a minimum of 4 – 50mm x 50mm x 3mm MS tags and bolted to either 8mm or 5/16th high tensile bolts to each piece with no protrusions.

Minimum requirement for foot protection be a minimum of roll cage material.

A plate may also be required. Fig. 10(iv)

Foot protection bar support 25mm x 3mm support from foot protection bar must attach to protector bar at one end and the other attached to barwork to the left.

Foot protection bar and brace bar is mandatory if drivers feet are past the “A” pillar bar whilst the driver is seated in the car in race position.

i) The bar providing the anchor points for the shoulder belts is to be positioned so that the belts are anchored a maximum of 300mm from the point at which the shoulder belt comes through the back of seat.

j) **Ballast weights may be used. If ballast is dislodged from a race car during an event a penalty of 12 months could apply.**

Ballast should be no greater than 610mm long x 100mm wide x 50 mm high. Each piece of ballast to be painted white with registered car number for identification.

Ballast must be attached to either roll cage or chassis and mounted below door height.

a) If attached to chassis, must be attached directly to chassis by utilizing high tensile bolts and nylok nuts. Bolts to go through chassis rail using proper engineering practice (sleeves)

b) If attached to the roll cage tubing, correct mounting brackets to be used eg: AFCO.

Maximum bolt on ballast allowed 40kg.

Each single piece maximum 10kg.

Ballast up to 305mm requires minimum one mounting bolt.

Ballast up to 610mm requires minimum two mounting bolts.

Bolts must pass through ballast.

Ballast to be mounted no higher than top nascar bar.

Fig 10
(iv – v)

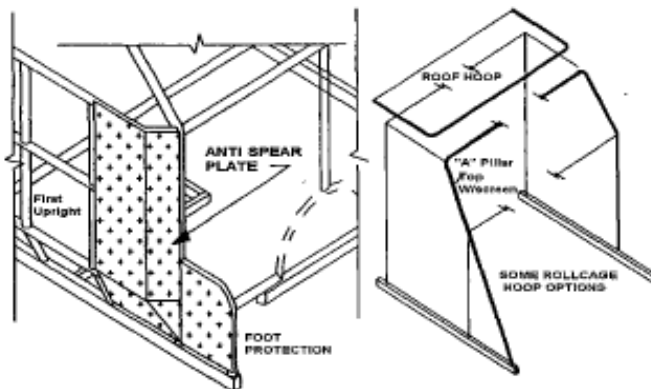

HEAD PLATE:

To simplify the removal of an injured driver it is highly recommended that a removable full size head plate be used: Fig. 11.

- a) Head plate to be of 5mm ALUMINIUM ALLOY or 3mm STEEL. 25mm x 3mm FMS strip to be welded to main hoop, top windscreen bar, centre roof bar and side roof bar. 10 of 50mm x 50mm x 3mm MS tags acceptable. Plate to be mounted, from above, with 10 x 8mm dia. High Tensile bolts, 3 each side, 2 front, 2 rear. Heads of bolts to be downwards, i.e. no projections.
- b) ALTERNATIVE head plate min. 3mm steel must extend from rear roll bar to top windscreen bar and from driver's side outer roof bar to centre roof bar. This plate must be securely welded to these bars with intermittent welding procedure.

Fig 11. Head Plate

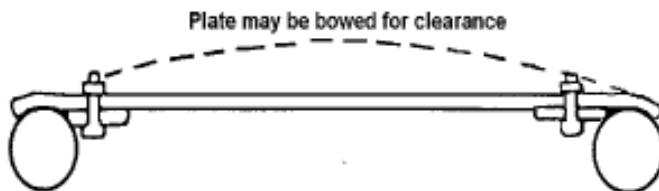

- c) Helmet clearance between roll cage roof/hoop bars for existing vehicles, may raise head plate as per drawing below Fig 11(i), to obtain 50mm clearance.

Fig 11 (i)



- d) Mounting procedure for raising of head plate (existing cars). 10 stubs 38mm x 3mm tube – stub length is determined by height required to gain 50mm clearance.
- e) Stubs to be end capped and threaded for mounting purposes.

15. TRACK:

Original plus 75mm maximum. Centre-line-centre-line, refer Fig. 12. (Wheel/tyre measured at stub axle height and averaged front and back)

16. WHEELBASE:

Original, within 1% ABSOLUTE. See also 7 "Measuring of Cars".

Fig. 12 Track and Rim Measurement

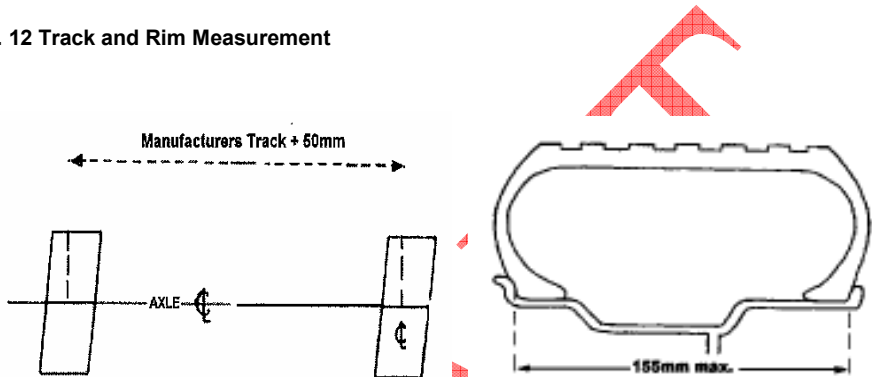

17. BUMPER BARS & OPTIONAL EXTERNAL BARWORK:

OEM type Steel bumper bars **NOT** permitted but may be replaced with max. 42mm x 3mm CHS.

- Bumper/s to be securely mounted in original position using supports of a minimum of 100mm from rear of bumper tube. Maximum support size, 42mm x 2.5mm CHS, 40mm x 40mm x 3.2mm RHS, or 50mm x 25mm x 3.2mm RHS only, i.e. gussets are not to be used. Bumpers are not to tie to under-guard bar work. (Fig. 13)
- Front &/or Rear: Original plastic bumper bar can be reinforced
- FRONT bumper Maximum return 300mm, Minimum 100mm by max. 42mm x 3mm CHS.

Front & Rear Bumper Bar: To be covered with a plastic road car bumper. Optional copy of fibre glass bumpers front & rear be allowed. To be exact copy of O.E.M Bumper for model. Plastic/fibreglass bumper bar covers are not allowed to have non OEM skirts fitted to bottom of bumper.

Plastic bumper cover must be fitted with round head bolts. Aluminum rubbing strips optional. 40mm x 3mm maximum aluminum strip may be fitted between bolts to support bumper cover.
Bumpers are to remain hollow.
Corners and the ends of front and rear bumpers to be radius formed, 100mm minimum.

Maximum of four mounting points on each bumper bar.

Returns and bumpers to be flush fitting with the body, within 25mm.

Anti hook-up bars from returns of Front and Rear bumpers to be extended onto the stay bars.

- d) REAR only: Returns of rear bumper may be extended as a skid rail against outside of body between bumper and wheel arch, and then extend inward to the "chassis rails".
- e) Corner plates on top edges of either bumper not permitted.
- f) Towing attachments will be via the override bars or a hole cut in the panel under the bumper, to allow the bumper pipe to be used to pick up the vehicle.

Fig 13

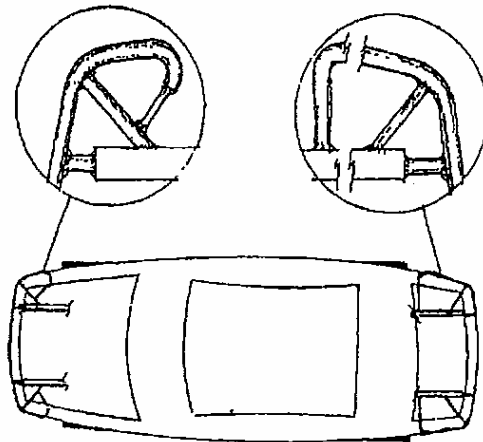

RUB STRIP MOUNTING

Fig 14 Rub Strip Mounting

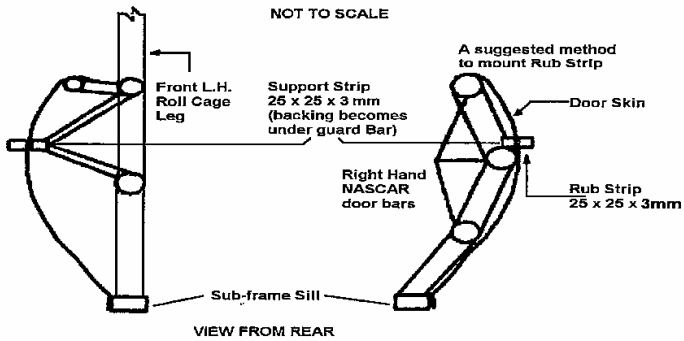

- f) Mild steel rubbing strip between wheel arches to be 25x25x3mm MS RHS or alternately, nylon (urethane, nolathane) 50mm x 12mm thick. Be securely mounted against body at a minimum of four points. Bolts to be evenly spaced. Bolts must be minimum of 8mm coach-head (cuphead) bolts and be bolted horizontally to bar work.

Fig 14 (i) Rub Rails

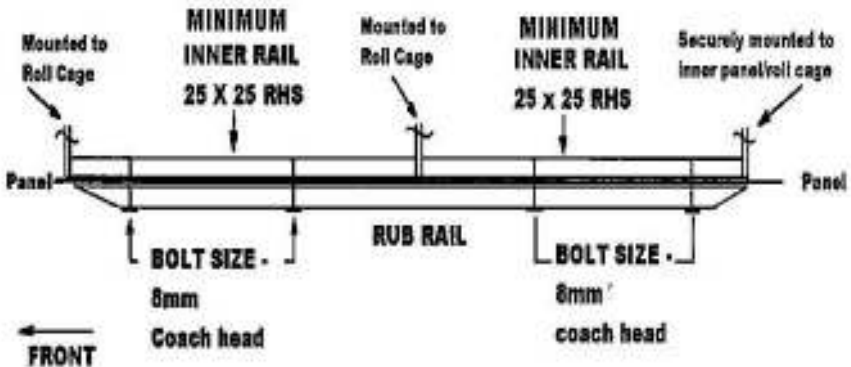

Bolts at each end must be no more than 50mm from the end of rub rail. Inner mounting bar, **minimum** 25 x 25 x 3mm, is to be returned to the chassis or roll cage at each end.

Rubbing rail ends to be closed and taper to 45 degrees as not to become a "spear". Fig. 14 (i).

Rub strips not to be used on quarter panel behind rear wheel.

Technical Committee will continue to monitor rub rails and if competitors are not adhering to the correct mounting procedure, rub rails will be removed from all Sections.

- g) **REAR OVERRIDE BAR;** An override bar may be used. Constructed of maximum 25mm OD x 3mm CHS it shall be no wider than the boot panel and shall be mounted centrally on the bumper bar at no more than four points, be VERTICAL and be max. 100mm high. Brace bars are not to be used.
- h) **FRONT OVERRIDE BAR:** An override bar may be used. Constructed of CHS maximum 25mm x 3 mm CHS, maximum 600mm long, 150mm high and mounted centrally on top of bumper at three points only, i.e. it may have a centre support. Fig. 15.

Fig 15 Front & Rear Override Bars

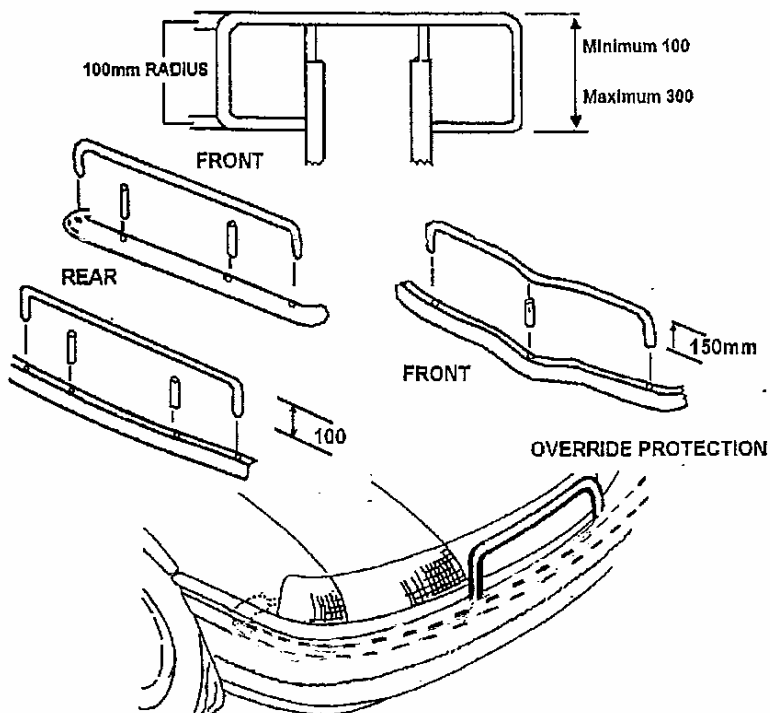

Pipe must be behind plastic bumper cover

18. ENGINE:

ENGINE - All of the components making the engine function, meaning complete engine, including rocker covers, excluding exhaust.

ENGINE SEALING IS COMPULSORY

All engines are to be sealed to enter events and details to be entered in page 8 of vehicle's log book.

Engine Seals for Production Class will be Green.

Engine Seals will be placed – 1 each side of Sump and 1 only on Timing Cover.

Engine to be mounted with rear face of engine block in the original position.

Engine offset is not permitted. For Placement - See Fig 6

- a) Maximum 6 cyl. Reciprocating engine to 4500cc absolute.
Maximum 2 valves per cylinder, after market roller cams and roller cranks not permitted. No rotary cars allowed.
Checks will be on fuel and OEM equipment.
Radio telemetry TO or FROM a car or cars will not be permitted.

b) **CARBURETTOR**

Single carburettor to be type and make for the model.

Additional adaptor/spacer block under carburettor not permitted.

Additional gaskets or thicker than standard gaskets not permitted in the carburettor, on spacer/adaptor, or on the manifold.

Additional fuel capacity for float chamber not permitted.

A carburettor with more than two throttle butterflies or throats not permitted.

Cars produced only in OEM multiple carburettor or OEM 4bbl carby. form, must use a "HOLLEY 350cfm" 2 barrel Carby, max. venturi I.D. 1.203 (30.56mm) and a suitable "bolt-on" adaptor block (maximum 25mm thick).

Persons wishing to build any late model car supplied in multi. Carby or 4 barrel form only, must apply in writing to the Federal Technical Committee for approval before it will be considered for registration. Application is to include full details of parent manufactures' manifold (not SPORTS option) to be used with a 350cfm. 2bbl Holley carby. and a 25mm max. "bolt-on" adaptor block.

Any adaptor block for Holley 350 carby, must be bolted to the manifold (not welded) and when removed, a standard carby, for that manifold must still fit the manifold and the engine be able to run in that form.

Inlet manifold to have no external modifications and to be OEM in appearance.

All cars fitted OEM with single carburettor may use "Holley 350 cfm" 2BBL on original manifold or an OEM manifold option for the engine, NOT a SPORTS option. Holley copies i.e. demon are not permitted to be used.

All "Holley 350" carby's maximum venturi internal diameter or 30.56mm.

Venturi will be checked using GO / NOGO gauge. Venturi is to be symmetrical and be affixed in position.

- c) Engine block to be of original type and make for model, not after-market alloy or iron replacement.

- d) Engine changes permitted if O.E.M. Ford to Ford, Holden to Holden (e.g. Buick is not Holden).
Race engine to be based on passenger car engine only.
Manufactures markings to remain on engine block castings.
Harmonic balancer optional.
- e) Crankshaft stroke not to be increased or decreased relative to the block being used.
- f) Cylinder head to be of original material, type, make and configuration.
- g) Engine to be mounted in original position, i.e., slant six retains the angle and vertical six remains vertical.
If resilient engine mountings are used, a wire cable or chain restraint must be fitted.
- h) Dry sump lubricant not permitted.
- i) Remote filters coolers, etc. to be isolated from driver by a 1mm firewall, mounted securely below door height, as to not impair vision through cabin.
All connecting hoses, couplings etc to be correct class of fittings for that purpose.
Remote oil pump permitted. External oil feeds to bearings permitted.
- j) Inlet manifold to be OEM option for engine but must be visually standard.
Spacer/adaptor between head and inlet manifold not permitted.
- k) Return springs must be fitted to each butterfly shaft (in-built springs accepted), and one spring to accelerator pedal linkage. Protective wire gauge or air cleaner to be fitted over air intake to prevent entry of foreign objects to the throttle body and also to act as a flame trap.
- l) That any use of upper Cylinder lubricant via carburettor or vacuum system is illegal. Any vehicle found with these type of systems will be deemed illegal.

18.1 EFI ENGINE

- a) Open computers and ignitions allowed.
- b) Engines to be limited to VY Commodore ecotec and AU Falcon. No variable cam timing. Inlet manifold to be OEM for model of engine. No high output or Tickford heads allowed. Original casting number on front of head must remain. EL Falcon not to use AU engine.
- c) All standard sensors must be fitted and be operating including fuel pressure regulator except oxygen sensor and coolant sensor. The use of knock sensors are optional
- d) All air intake and air filters are not restricted.
- e) Header tanks for fuel pumps are not allowed.
- f) No adjustable fuel regulation.
- g) Harmonic balancer is not restricted.
- h) Flywheel and clutch assembly not restricted.
- i) Camshaft and camshaft timing parts are not restricted. Camshaft lifters to be solid or hydraulic. The use of performance parts in the valve train is prohibited.
Eg: roller rockers, cam followers etc.

- j) A standard engine is allowed no more than 0.60" overbore and 0.60" for head facing.
- k) To fit V6 ecotec engine into a VE Commodore the sump will need to be modified. Sump modification is to be done by Castlemaine Rod Shop. The sump capacity will remain the same. Castlemaine Rod Shop will stamp the sump with a part number.
- l) Refer: Australian Standards "AS4182-1994 Code of Practice for Engine Reconditioning Standards".
Engine balancing: The balancing of any engine componentry or removal of any balance shaft is strictly prohibited. The only tolerance allowed are the drill holes on the crank shaft as done by the manufacturer (OEM). The conrods cannot have any metal removed or polished. The pistons cannot be machined or lightened.

18.2 EFI ENGINE

- a) Standard size injectors are to be used. Inside diameter not to be increased or decreased.
- b) Petroleum, no additives, maximum specific gravity 0.780, maximum octane 98. Must be supplied by a commercial outlet, through a multi volume network via bowser pump by Shell, Caltex, Mobil or BP only. Fuel may be tested by any means available.
- c) Any passenger car fuel pumps only are permitted. Fuel pump must be fitted with engine monitoring relay to stop fuel pump running when engine stops.
- d) A flexible fuel line section must be fitted within 75mm of the fuel tank and all fuel lines to be securely fixed in position.
- e) Barbed fitting of the correct size must be used in conjunction with screw type clamps when connecting flexible fuel line. (Genuine SAE R6 fittings and hoses exempt)
- f) Neoprene, reinforced plastic or "black fuel line" may be used. OEM type Bundy steel tubing may be used through the car or under the car.
- g) Flexible fuel line can pass through cabin area. Must be one piece.
- h) High pressure lines are to use high pressure hose and fittings.
- i) If a return line is used, it must be fitted with a one way valve, at the tank.
- j) Computer Control Units are not restricted. If OEM unit includes ignition, then the replacement CCU must also perform this function.
- k) Size of throttle body to be OEM type and size for model being used and to be standard in internal and external appearance. (No machining or alteration permitted)
- l) Checks will be on fuel and OEM equipment. Any modifications to throttle body or butterfly is not permitted.
- m) Radio telemetry to or from car is not permitted.
- n) Non OEM fuel injection not permitted. Forced induction not permitted.
- o) Return springs must be fitted to each butterfly shaft (inbuilt springs accepted)

- p) Protective wire gauze or air cleaner to be fitted over air intake to prevent entry of foreign objects to throttle body and also to act as a flame trap. Air filter and air flow meter may be used in cabin or moved under the bonnet. Air filter inlet to be shrouded from the driver. Must be under the bonnet if passenger in the car.
- q) ADDITIVES: The introduction into the combustion chamber/s of additives, either in solid, liquid or gaseous form (eg nitrous oxide) by any means is expressly forbidden.
- r) Engines will be inspected on the basis that all parts used in/on all engines must comply with the specifications/dimensions specified in the original (OEM) manual produced by the manufacturer for the standard engine: with the exception of the listed permitted modifications. The owner/driver is responsible to prove the above and produce information when necessary to validate the claim.

THE ABOVE ITEMS ARE SUBJECT TO REVIEW.

19. BATTERY AND ELECTRICAL SYSTEM:

- a) Battery to be securely mounted in a box or metal frame secured to roll cage or bar work. Fig 16.
A non-conductive covering be placed over the battery and the exposed metal of the cable terminals to reduce acid spillage and to reduce chance of arcing if metal contacts battery in any incident if in cabin area.
The maximum size battery that can be used is N70ZZ.
Cabin mounted battery, must be secured by an angle iron frame(25mm x 25mm) both top and bottom with 8mm bolts or rods.

Fig 16 Example Only

BATTERY CLAMP/HOLD DOWN FRAME

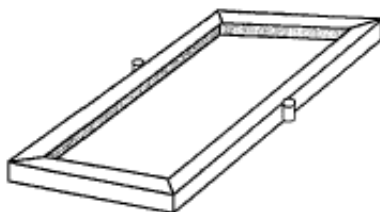

FRAME: 25 X 25 X 3mm ANGLE IRON

- b) Suitable grommets must be fitted where battery cable passes through metal firewalls.
- c) At the commencement of a meeting, car must be capable of starting with starter motor
- d) Switches: Ignition switch and electric fuel pump switch, if fitted, must be grouped together and be clearly marked.

- e) An engine "KILL" switch, suitably marked with a contrasting colour, must be fitted in the centre of "cowl panel".
- f) Electrical switches NOT to be mounted through the floor.

20. EXHAUST SYSTEM:

- a) Exhausts must be within local noise level requirements. Recommend 95dB.A.
- b) All exhaust gases are to be directed away from all drivers, fuel tanks and tyres.
- c) Internally ducted exhaust system shall vent through the body not higher than 100mm above the door sill panel, using a slip joint as in Fig. 17.
Driver to be suitably insulated from exhaust system. Insulation and firewall sheeting not to exceed 150mm above drive shaft tunnel.
- d) Exhaust systems to have not more than two outlet pipes, and not protrude beyond body line.
If exhaust system is under floor, safety chains will be fitted to front and rear of pipes and secured to floor pan or sub-frame.
Pipes and mufflers must be securely attached to the vehicle.
- e) Sheeting to cover exhaust to be within 50mm of exhaust, no other extra sheeting allowed in cabin area.

Fig 17. Internal Exhaust Duct Body Vent

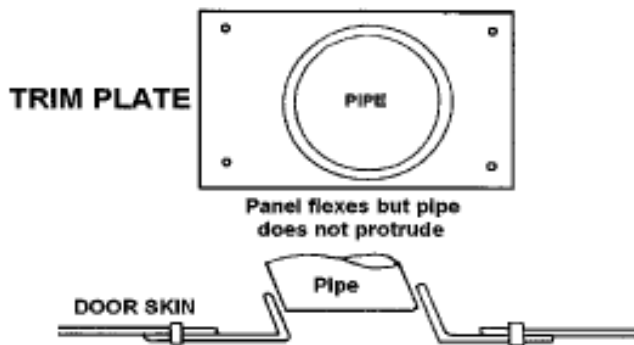

Any car exhausting excessive unburned fumes while on dummy grid, or being formed up on the track, may be excluded as this constitutes a health hazard.

21. COOLING SYSTEM:

- a) Cooling system may be modified.
- b) All radiator hoses to be of fabric reinforced material, plain rubber hoses not permitted.
- c) Radiators may be mounted inside cabin provided that they are mounted as low as possible in the rear of the vehicle and suitably isolated from the driver. The upper half of rear window opening MUST NOT be obscured by the rear radiator.

Radiator ducting shroud, if used, maximum of 600mm forward of the radiator and must not be more than half the rear window height.

- d) Cabin mounted radiators must have BOTH tanks totally covered to protect driver in the event of a cap or tank blowing.
- e) Pipes leading to the radiator to be of steel, aluminium or copper pipe. All internal pipes to be ducted or lagged with suitable material.
- f) Hoses to be as short as possible and fitted to radiator from rear side.
- g) Exposed hoses or joints not permitted in cabin area.
- h) Cabin mounted fans to have shroud or suitable guard.
- i) Cabin mounted water pumps must be lagged or covered by suitable guard.
- j) All header tanks, hoses and caps in cabin area to be covered, and must be mounted below half window height.
- k) Radiator water spray systems are not allowed.
- l) Cooling system to have a manual pressure relief tap/cap fitted. Lever vent type may be used. Tap to be fitted with a hose to direct steam to the ground.

22. TRANSMISSION:

ELECTRONIC TRACTION CONTROL NOT PERMITTED.

Every race car is to be fitted with a clutch so that the engine may be started and then the vehicle can be put into gear and move off in forward or reverse as required.

- a. Gearbox must have a minimum of two forward gears and reverse gear.
- b. Late model bodies using early engines must use the original diff. complete with all mountings, in the original position and being used. Ratio's are free.
N.B. Cars from EA Falcon and VN Commodore onwards CANNOT USE A 9' DIFF.
All drive line components must be derived from mass produced passenger cars and remain visually standard externally.
Coil Spring mounts on Falcon differential must be in original position and being used.
- c. Internal modifications are permitted except that the use of "quick change" systems in the driveline is specifically prohibited,
- d. For SAFETY "full floating" rear axle assembly recommended. Conversion to floating hubs permitted.
- e. Rear axle assembly to be of original type.
- f. Scattershield: All cars must fit a Scattershield. To be a minimum 3mm x 150mm wide and must cover the upper 180 degrees of bell housing and be securely attached to the bell housing or fire wall in engine bay, or front fire wall in cabin area, to protect the drivers feet and legs from clutch explosion.
- g. Tail shaft may be of one piece or two piece types, conversion is optional.
- h. No carbon fibre tail shafts allowed.
- i. Tail shaft/s must be fitted with 360 degree hoops at front and rear.

Tail Shaft Loops - Steel strap minimum. 40mm x 5mm or 6mm chain or 6mm wire rope to be SECURELY fitted around the front and the rear of the tail-shaft within 150mm of universal joints to prevent the tail-shaft and/or shafts from dropping in an event of breakage.

- j. Tailshaft/s must have fully operational constant velocity/universal joints, be suitable for the application and be correctly phased.

REAR AXLE BEARING RETAINING RINGS. If using assembly not fitted with floating axles, a new retaining ring must be fitted at replacement of bearing or axle. Ring must be an interference fit with the axle, when in place the retaining ring is to be tack welded using MIG or a small diameter low hydrogen rod on low amperage.

FAILURE TO OBSERVE THIS PROCEDURE WILL INCUR A PENALTY ESPECIALLY IF AN AXLE IS DISLODGED. (SAFETY DECLARATION)

WHEEL STUDS. Grade 8, 12mm minimum all vehicle except Mini (7/16" for use with 10" wheels only)

23. STEERING:

- a) Original type must be used. E.g. Rack remains rack. May be modified.
- b) Must be in sound condition. Steering joints to be split pinned as required.
- c) Wire spoke or wood rim steering wheels not permitted.
- d) Steering column to be securely mounted to the roll cage dash bar.
- e) Hub of steering wheel to be padded with dense resilient foam and covered.
- f) To reduce thumb and wrist injuries, the use of "PAW SAVER" type disc steering wheel is permitted.
- g) Quick release steering wheel optional.
- h) Steering quickness may be used.

24. SUSPENSION:

- a) A Production race car must use a complete metal body with the suspension mounting points in original position and being used.
- b) Suspension mounting points are defined as:-Mounting points of suspension arm, either end; shock absorber, either end; strut, either end. Shock absorber either end may have a tolerance of + or - 25mm maximum overall for mounting purpose.
- c) The use of Torsion Bars, unless original equipment, is illegal. Fitment of a Mitsubishi L300 front stub axle is permitted to be used on Cortina.
- d) Front and Rear Suspension to remain of standard type except that the use and position of Panhard bars and/or sway bars is optional.
- e) Suspension arms may be fabricated, must retain original designed function and must not vary in length whilst in motion.

- f) Suspension components must attach directly to original mounting points. Original front cross-member to be used, except VN-VS Commodore must use VB – VK cross member and AU Falcon be allowed to use EA/ED cross member when using early model engine.
Straps for mounting shockers or suspension arms etc. NOT permitted,
Coil over unit is not equivalent of coil spring plus shock absorber.
- g) Original front stub axles must be used.
Front hubs to be of a mass produced passenger car type and mount directly to original stub axles.
Commodore VS onwards: stub axle bearing carrier assembly is classed as a stub axle assembly.
Each replica hub is to be fabricated from one piece of a suitable grade of aluminium or steel alloy.
- h) When McPherson or Chapman strut suspension system is used, the vehicle manufacturer's original stub axle and shock absorber tube MUST be retained and used.
The lower spring mounting may be adjustable.
- i) Any McPherson type front strut must use the original mounting point bolt holes in the original position on the body. Strut brace between towers permitted.
- j) Weight jacking systems incorporated into the spring mountings are permitted but are not to be adjustable from the Driving seat.
- k) 5th ARMS, lift bars or any derivatives are not accepted in this Class.
- l) Shock Absorbers/Strut Inserts: Adjustable shock absorbers permitted, provided no adjustment can be carried out from cabin or from drivers seat or whilst on the dummy grid or race track.
No external reservoir/canister type or externally gas pressure adjustment, (e.g. increase/decrease gas pressure).
- m) Additional shock absorber/s, strut bar/s and/or spring/s not permitted.
- n) Rear leaf springs: are to remain visually standard, fore and aft of the U bolts, including shackle plates.
Lowering blocks not permitted.
- o) In AU Falcons the aluminium cross members may be reinforced as per Specification Book

25. WHEELS:

Wheel studs are not to protrude further than ½ " (12mm) past outer face of the wheel nut.

- a) 177mm (7") maximum width. Bead lock attachment NOT permitted.
- b) Wheels must be in good condition and free from cracks.
- c) Wide Five style wheels, hubs and adaptors NOT permitted.
- d) Dual stud pattern drilling is NOT permitted.
- e) Wire wheels and/or dual wheels not permitted.
- f) Balance weights to be securely fastened or taped.
- g) Rim edges to be rolled or rounded off if rim protrudes past the tyre side wall.

- h) Covering not to be welded to outer section of rim.
- l) Wheels may be reinforced provided they meet with the approval of the State Technical Committee or the Chief Scrutineer.
- j) **"Mag" Wheels:-**
Correct matching nuts and washers must be used.
Composite type wheels NOT acceptable.
Composite wheel means wheels made of different materials. E.g. 3 piece alloy wheels are not classed as composite wheels.
- k) **Steel centre wheels:-**
Heavy Duty "Off Road" type centres preferred to flat plate.
Wheel centre hole to be chamfered.
Stud holes to be chamfered to suit the nut used, and to be chamfered on inner edge also to relieve guillotine action on studs.
Right hand front wheel, if of flat steel plate, to be of not less than 10mm thickness; if dished centre, min. 5mm. thick absolute.

26. TYRES:

- a) Tyres—Radials only: Minimum 60 series profile:
Speed rating: up to and including "V" maximum, including recapped tyres.
- b) Details are to be visible in OEM markings on tyre sidewall. (e.g. 265/60R 15 V or 265/75R 15 V)
- c) No performance tyres permitted – e.g. Hoosier, American Racer, McCreary etc.
- d) Road legal re-tread tyres permitted.
- e) Safety inner air tube be allowed.
- e) Tyres will be reviewed annually.
- f) Retread tyres must have the correct remoulders speed rating etc. and be legible as per AS 1973 - 1985

27. BRAKES:

- a) Foot operated hydraulic brakes to be fitted and be effective at race speeds.
- b) Brakes to be fitted to a minimum of three (3) wheels.
- c) Right hand front brake only may be removed.
- d) Electronic ABS not permitted. Adjustable brake systems permitted.
- e) No carbon fibre components to be used.
- f) Disc rotors may not be altered by drilling of rotor surface* note some discs are supplied from the factory as drilled disc(ie: DBA, Willwood)

28. FUEL:

- a) **ULP ONLY**
- b) **GAS**; E.g. LPG or CNG is NOT PERMITTED.
- c) **PETROLEUM**; No additives, maximum specific gravity 0.780, max. 98 octane. Must be supplied by a commercial outlet through a multi-volume network via bowser pump by Shell, Caltex, Mobil or BP ONLY. Fuel may be tested by any means
- d) **NITRO**; The introduction into the combustion chamber/s of nitro fuels and/or additives, either in solid, liquid or gaseous form (e.g., nitrous oxide) by any means is expressly forbidden.
- e) Ignition not restricted.
- f) Use of cooling systems for fuel is not allowed

29. FUEL TANK AND FUEL SYSTEM:

- a) Original fuel tank must be removed and replaced by a tank/s of up to 72 litres for petrol. Fuel tank not to be mounted using brackets welded to tank or cell. Area beneath tank to be cut out, giving adequate ventilation and ensuring that spillage cannot remain in vehicle. Pressurised fuel tank/s NOT permitted.
- b) Filler cap to be a positive seal, behind a firewall and inside body. Levers on cam locked caps to be clipped.
- c) Metal fuel tanks over 25 litres must be baffled. All joints to be welded to a professional standard.
- d) Fuel tanks to be constructed of minimum 1.0mm steel or 3.0mm aluminium alloy.
- e) Competition type "plastic" tank highly recommended.
- f) All fuel tanks to be constructed with pick-up fittings etc. coming from top, bottom or side of tank.
- g) If pump is placed in an existing tank, then low outlets are to be blanked off and outlet moved to the top.
- h) A flexible fuel line section must be fitted within 75mm of fuel tank and all fuel lines to be securely fixed in position.
- i) Barbed fittings of the correct size must be used in conjunction with screw type clamps when connecting flexible fuel line. (Genuine SAE R6 fittings and hose exempted).
- j) Neoprene, reinforced plastic or "Black Fuel Line" may be used. OEM type Bundy steel tubing may be used through the car or under the car.
- k) Flexible fuel lines can pass through the cabin area.
- l) High pressure lines are to use high pressure hose and fittings.
- m) The fuel line to the engine must be fitted with a quick action NON - LEAK fuel tap or valve, in working order. EXCEPT EFI CARS
- n) The actuator or switch is to be mounted within easy reach of driver and crash crew, and clearly marked "FUEL" ON/OFF.

- o) Solenoid valves or remote mounted fuel taps are permitted.
- p) If a return line is used, it must be fitted with a one-way valve.
- q) Electric fuel pumps must be wired with an independent earth. The pump **MUST** be controlled by the 'KILL' switch AND by an engine monitoring relay -this device is highly recommended.
- r) Fuel lines **MUST BE ISOLATED** from electrical wiring.
- s) The use of an approved type fuel cell and receptacle is recommended.
- t) Tank/s to be securely mounted in the boot area of the car, in a suitable metal cradle attached to the bar work, with a minimum clearance of 150mm forward of the lower rear end of the boot panel and 300mm minimum from side of vehicle, and isolated from driver by a firewall.
Tank to be protected by substantial bar work on all sides.

Fuel tank protection: Bar must be constructed of minimum 38mm x 3mm CHS or 40x40x3mm RHS and be 25mm clear all around tank and filter, projecting a line from the rear wheel centre to the bar. Bar is to prevent side entry to tank by nose of another vehicle.

Fuel tank protection bar must have radius formed corners as per diagram Fig 18. No straight side pipes for jacking to extend.

Underslung fuel tank is a fuel tank that has some portion below the bumper tube or chassis rails and therefore is to have a fuel tank protector bar fitted.

Protector must be 25mm lower than an underslung tank and mounted as per Fig 18 (Brace bars do not constitute Bumper mountings.)

- u) Tank vents to be fitted with an anti-spill device.

Fig 18 FUEL TANK PROTECTOR

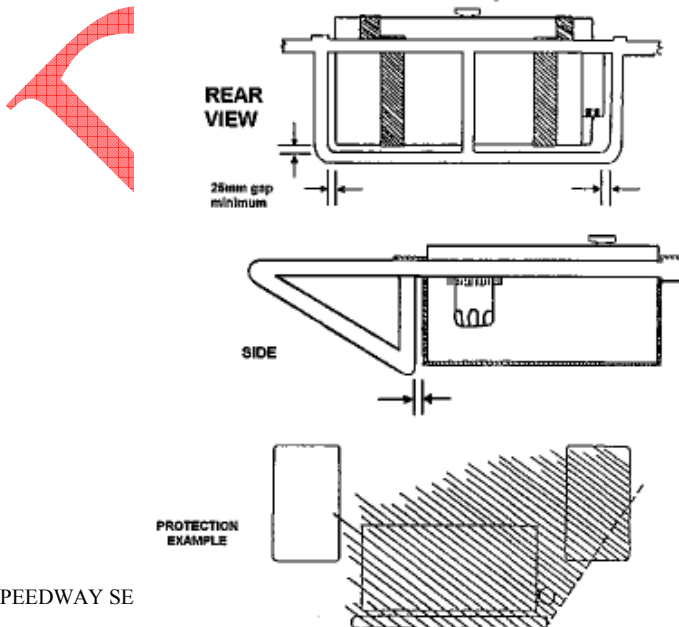

Table 2 - ENGINE FOR MODEL

MODEL	STANDARD BORE	STROKE	“ENGINE”
HOLDEN			
U, LHILX	3.625 (92.075mm)	3.25 (82.55mm)	202 in-line 6
VB—VZ	3.625 (92.075mm)	3.25 (82.55mm)	202(later 3300)
TX Gemini	3.2283 (82mm)	2.9528 (75mm)	1600 OHC 4
FORD			
TD--TF Cortina	3.6811 (93.5mm)	3.9093 (99.3mm)	4.1 L in-line 6
XD—BA Falcon	3.6811 (93.5mm)	3.9093 (99.3mm)	4.1 L in-line 6
Escort	3.1882 (80.98)	3.0563 (77.62mm)	1600 OHC4
Escort	3.5755 (90.82mm)	3.0295 (76.95mm)	2000 OHC4
CHRYSLER-MITSUBISHI			
Centura	3.76 (89.4mm)	3.68 (93.5mm)	245 Hemi in-line 6
Charger	3.91 (95.5mm)	3.68 (93.5mm)	265 Hemi in-line 6
Colt RB/RC	2.874 (73mm)	3.3858 (86mm)	1400 OHC4
	3.0275 (95.5mm)	3.3858 (86mm)	1600
Sigma	91.1mm	98.0mm	2.6L Astron II
TOYOTA			
Celica	3.3465 (85mm)	2.7559 (70mm)	2T in-line 4
	3.31 (84mm)	3.5 (89mm)	21 R in-line 4
	3.48 (88.5mm)	3.15 (80mm)	18R DOHC 4
EFI ENGINES			
Falcon	92.26	99.31	4.0 Lt
Commodore	86.00	85.00	RB 303.0Lt
Commodore	96.52	86.36	V6 3.8Lt
VALVE SIZES		INTAKE	EXHAUST
EA Falcon 3.9 Lt		47.00	39.00
EB-EL Falcon 4.0Lt		47.00	39.00
AU Falcon 4.0Lt		47.00	41.00
Commodore RB30 3.0Lt		42.10	35.10
VN-VR Commodore V6 3.8Lt		43.40	37.80
VS Commodore Ecotec 3.8Lt		45.50	38.50
VT-VY Commodore Ecotec 3.8 Lt		46.63	38.74

TABLE 3 - DIMENSIONS - Note: - Front & Rear Track include + 75mm

MODEL	WHEELBASE	FRONT-TRACK-REAR	
	mm	mm	mm
HOLDEN			
LJ Torana	2540	1396	1370
LH/LX Torana	2591	1472	1447
UC Torana	2591	1490	1457
VB—VK Commodore	2668	1525	1495
VL Commodore	2668	1525	1508
VN Commodore	2731	1530	1555
VP Commodore	2731	1526	1553
VR-VS Commodore	2731	1566	1566
VT-VX Commodore	2788	1645	1665
VY Commodore	2788	1645	1665
VE Commodore	2915	1677	1693
TX Gemini	2404	1375	1385
FORD			
TD Cortina	2581	1497	1497
TE Cortina	2578	1501	1501
TF Cortina	2580	1495	1495
XD Falcon	2818	1635	1601
XE Falcon	2818	1627	1612
XF Falcon	2829	1622	1600
EA Falcon	2794	1621	1608
EB Falcon	2794	1629	1608
EF - EL Falcon	2791	1641	1622
AU Falcon	2793	1641	1622
BA Falcon	2829	1628	1646
Escort	2400	1335	1355
MkII Escort	2407	1345	1371
CHRYSLER-MITSUBISHI			
KB/KC Centura	2667	1495	1485
CL Valiant	2819	1556	1566
RB/RC Colt	2380	1445	1415
GE/GH Sigma	2515	1445	1425
GJ/GN Sigma	2530	1455	1425
TOYOTA			
Corona	2500	1450	1425
Celica 82 onwards	2500	1450	1425
Celica TA22	2425	1355	1360

NISSAN

Datsun 200B	2500	1420	1420
Nissan 300ZX	2570	1570	1610
Datsun 240K	2610	1435	1415

MAZDA

Mazda 323-80	2315	1370	1385
--------------	------	------	------

HONDA

Honda Breeze	2570	1550	1540
Honda CX	2620	1550	1550
Honda DX	2500	1525	1530
Honda GL	2380	1475	1490
Honda GLI	2570	1550	1540
Honda SI	2620	1550	1540
Honda Grand Prix	2380	1525	1530

TABLE 4 – TYRE SPEED RATINGS

SPEED SYMBOL	SPEED RATING	
--------------	--------------	--

S	180	kmh
T	190	kmh
U	200	kmh
H	210	kmh
V	240	kmh

TABLE 5- THROTTLE BODY

THROTTLE BODY	OUTER	INNER
EA-AU Falcon	64mm	64mm
VL Commodore	64mm	54mm
VN-VR Commodore	72mm	60mm
VS-VY Commodore	72mm	64mm

DRAFT