

TABLE OF CONTENTS

1.	INTERPRETATION.....	3
2.	AUTHORITY TO EXCLUDE.....	3
3.	GENERAL.....	4
4.	CONSTRUCTION.....	4
	GLOSSARY OF TERMS & DEFINITIONS.....	4
5.	DECLARATION OF COMPLIANCE.....	5
6.	REGISTRATION.....	5
7.	MEASURING OF CARS.....	5
	Fig 1: Wheelbase Calculator.....	6
8.	PENALTIES.....	6
9.	DRIVER SAFETY.....	7
	PROTECTIVE CLOTHING.....	7
	Helmet.....	7
	Seat Belt.....	8
	Fig 2. (i & ii) Restraints.....	8
	Fig.3 (i – iv) Restraint System.....	9
	INSTALLATION OF DRIVER RESTRAINT SYSTEMS.....	9
	ADJUSTMENT OF DRIVER RESTRAINTS.....	10
	WINDOW NET.....	11
	Fig 4 Window Net.....	11
	Fig 4 (i).....	12
	Padding.....	12
	Fire Extinguisher.....	12
10	SEAT.....	12
	Fig 5 Typical Seat.....	13

CLASS SPECIFICATION

11	CLASS CRITERIA.....	14
12	DIRECTION OF RACING.....	14
13	STREET STOCK DERIVATION.....	14
14	BODY.....	14
	Fig 6 Rubbing Strip.....	15
	Fig 7 Bumper Bars.....	17
	Fig 7 (i) Bumper-to-bumper kit.....	17
	Additional Firewalls.....	18
	Fig 8 Triangular Roof Number.....	18
15	ROLL CAGE.....	19
	Fig 9 (i) Typical Roll Cage.....	20
	Fig 9 (ii) – (iii) Cage Details.....	20/21
	Additional minimum Bar work.....	21
	Fig 9 (iv - v) Alternative Cage Details.....	23

16	HEAD PLATE.....	24
	Fig 10 Head Plate.....	24
	Fig 10 (i) Raised Head Plate.....	24
17	ENGINE & AUXILIARY EQUIPMENT.....	25
18	ELECTRONIC FUEL INJECTION.....	27
19	CARBURETTOR.....	28
20	ELECTRICAL.....	28
21	EXHAUST SYSTEM.....	29
	Fig 11.....	29
22	COOLING SYSTEM.....	30
23	TRANSMISSION.....	30
24	SUSPENSION/STEERING.....	31
25	WHEELS/TYRES.....	32
	Fig 12.....	32
26	BRAKES.....	33
27	FUEL TANK AND FUEL LINES.....	33
	TABLE 1 Engine list.....	34
	TABLE 2 Bore & Stroke.....	35
	TABLE 3 Valve Sizes.....	35
	TABLE 4 Carburettor List.....	36
	TABLE 5 Throttle Bodies.....	36
	TABLE 6 Computer And Injector List.....	37
	TABLE 7 Standard Dimensions.....	38
	TABLE 8 Tyre Ratings.....	39

PLEASE NOTE: Where possible the data in the Specification Manual has been taken from the Glass's Directories, which is the main reference book used by the SSA Inc. Information that is not available in the Glass's Directories, is taken from Manufactures Workshop Manuals. We have checked and cross checked the information in this Manual. If you do find something that does not seem to be right, anywhere in this Specification Manual, please let us know immediately, so that we can check it out and if it is wrong, we can change it.

© **All rights reserved. Reproduction or translation of this Manual, in whole or part is not permitted without written authorization from Speedway Sedans Australia Inc.**

SPEEDWAY SEDANS AUSTRALIA Inc. SPECIFICATIONS

INTRODUCTION

1. INTERPRETATION:

The Speedway Sedans Australia Inc. (SSA Inc.) shall direct the enforcement of these specifications in all aspects.

The SSA national technical committee shall be the sole authority for the interpretation of the specifications as contained in this book and any circularised amendments.

AMENDMENTS to this Manual may be made during the life of this Manual for the reasons as set down in SSA Inc. Policy governing such amendments. The amendments will be approved by the SSA Inc. Board and circularized to all Clubs and competitors by way of a Media Release and/or in Tek Torque. A stick-in advising this amendment will be provided in the front of all Manuals purchased after the amendment becomes law. Amendments circularized in such manner, shall be deemed to be as valid as the contents of this manual and must be adhered to by all Competitors and Scrutineers.

Specific decisions made by Federal/State/Zone Officers shall be subject to ratification by the Federal Technical Committee, after due notice of the decision and reasons have been given. All enquiries must be directed to your local Club Scrutineer.

SSA Inc. cars must only race with SSA Inc. Registered cars, with SSA/Speedway Australia licenced drivers with SSA Inc. approved Insurance

2. AUTHORITY TO EXCLUDE:

If an SSA Inc Official determines prior to the race that the Race Car does not meet the applicable specifications, the car will not be allowed to compete unless, in the discretion of the official, the deficiency:-

- a. will not adversely affect the orderly conduct of the race.
- b. will not provide the competitor with a significant competitive advantage over other competitors.
- c. is so insubstantial as not to warrant a determination that the car is ineligible to race.

If the Official permits the car to compete under these circumstances, the Official will advise the competitor in writing of the deficiency, and if the deficiency has not been corrected, within the allotted time frame, the car will be prohibited from competing in any future event.

3. GENERAL:

Specifications listed in this book are a guide to building race cars unless otherwise specified. If "IT" is not in the book, enquire for prior clarification or approval. Before constructing cars of unusual or unconventional design, full details are to be submitted in writing to the SSA Inc Technical Committee via Club and State Secretary. If requested, this submission shall be handled "CONFIDENTIAL", and approval or required modification before approval shall be given in writing to the applicant. A fee applies.

4. CONSTRUCTION:

Workmanship on race cars is to be of professional standard.

All materials used must be of good quality.

Bolts are not to be used through structural tubing in the roll cage cabin area unless a welded sleeve is provided. No pop rivets in roll cage tubing.

All material sizes quoted are minimum unless a maximum is stated.

Transponders are to be fitted a maximum of 450mm forward of the front axle centre line.

Reshelling of a currently registered race car is permitted if same make and model and no fee is payable.

GLOSSARY OF TERMS & DEFINITIONS:

Material:

CHS - Circular Hollow Section.

RHS - Rectangular Hollow Section.

W.T. - Wall thickness.

FMS - Flat mild steel

OD - Outer diameter

AS1163 Gr300 - Australian Standard 1163 for structural steel tubing Grade 300

OEM - Original Equipment Manufacture; used to indicate parts used or the complete vehicle as it left the production line from the original manufacturer and means for make and model unless otherwise stated.

ENGINE - All of the components making the engine function, meaning complete engine, including rocker covers, excluding exhaust.

CARBURETTOR - Is to have all working parts in use, e.g. needle and seat, fuel bowl, float, jets etc and fuel is to be naturally delivered to the main jet by atmospheric pressure. The air pressure in the carburetor venturi being lower than atmospheric pressure, allows fuel then to flow from the bowl to the carburetor venturi as the pressure in the carburetor throat decreases. Fuel is then drawn down the venturi and carburetor throat by vacuum provided by the rotation of the engine.

Carburettors that are of different configuration than that of the above must be submitted to the Federal Technical Committee for permission to use. A complete description must accompany the submission to substantiate your request.

5. DECLARATION OF COMPLIANCE:

The PERSON RESPONSIBLE for the LEGALITY of the car, will complete an SSA Inc DECLARATION OF COMPLIANCE ANNUALLY.

Declaration will cover ELIGIBILITY for class and ALL points of SAFETY including material specification and sizes.

Details of the declaration are to be placed in the log book.

REGISTRATION IS NOT COMPLETE UNTIL Pages 3 to 7 of the LOG BOOK are completed and signed by both the Owner/Driver and the Scrutineer / Machine Examiner or Registrar.

Structural or other specification changes made during the year MUST be notified to the respective Officials and adjustments will be made to the Log Book if required.

The Driver must have an SSA Inc/Speedway Australia licence and an SSA Inc. infringement card.

6. REGISTRATION:

An SSA Inc new registration can only be issued for a race car, provided that the car conforms to the SSA Inc Specification Book for the Class in which the car is to be registered.

The car must pass an annual registration examination and a registration decal will be issued and must be attached to a prominent location on the car.

A car being re-registered must have the log book from the immediate previous season otherwise the chassis area and roll cage will be subject to new car specifications.

The DRIVER is responsible for having the log book further endorsed before participation in each official practice session or race meeting.

A log book without endorsement by the Machine Examiner is equivalent to a no-race ticket.

7. MEASURING OF CARS:

All cars are subject to engine and general measurement at any time by a Scrutineer, State or Federal Technical Committee OR at the direction of the Federal Technical Director, or the Federal Technical Committee, or the Steward or the Racing Disputes Committee.

The SSA reserves the right to impound and inspect any race car at any time, this may include removal of any seals for inspection and if found non compliant,

registration may be revoked

Cars can be selected and ordered to the impounded area for dismantling. The entrants of the cars must deliver them immediately upon request and supply the necessary manpower and hand tools to accomplish dismantling.

Only persons actually involved in dismantling the car will be allowed in the immediate area of a vehicle being checked. Persons associated with other cars being checked are to remain with their own car.

Any persons not having cars in the impound area, and gaining entry without authorisation, will be ejected.

If there are no facilities for ready check of any parts of a vehicle, sealing of parts under question can be carried out and vehicle taken to a mutually agreed venue for examination at another time, but within fourteen (14) days.

Impounded cars will be stored at the owner's risk. Although every reasonable precaution will be taken, no responsibility for fire, theft or damage will be assumed by the SSA Inc and/or affiliated clubs.

Fig.1.

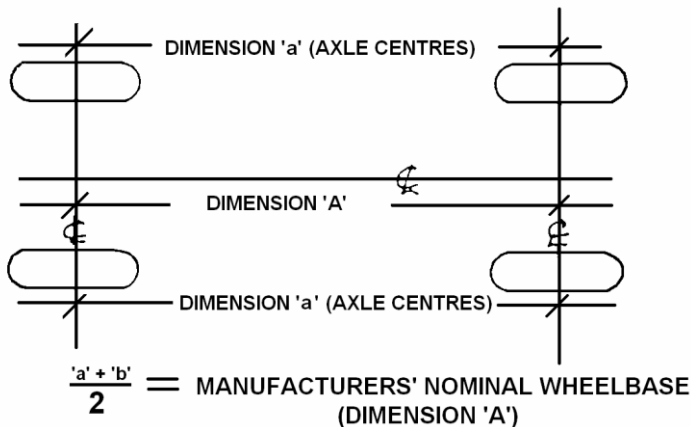

Method of measuring wheelbase shall be;- With each front wheel pointing straight ahead, measure distance from front axle centre to rear axle centre on each side of vehicle. Add dimensions for left and right, divide by 2. Allowable tolerance +/- 1%.

All engines are to be sealed to enter events.

8. PENALTIES:

This Manual must be read in conjunction with the Australian Speedway Racing Rules and Regulations and/or notices issued by the SSA Inc. from time to time.

Ignorance of these Regulations and Specifications and notices shall be deemed as no defense in regard to breaches and/or appeals of same.

9. DRIVER SAFETY:

All protective clothing and safety equipment must be used and/or worn in the approved and accepted manner whilst competing, or testing and/or practice.

All race wear / equipment to be inspected at each practice/race meeting.

PROTECTIVE CLOTHING:

The following are minimum safety standards:-

RACE SUIT: Minimum standard of either SFI 3.2A/1 or the higher standard of apparel, a snug fit at ankles, collar and cuffs, and must be fully fastened at all times whilst in the car.

UNDERWEAR: Comply with SFI 3.3, FIA 8856-2000 and must be worn. Drivers must only wear cotton socks and under-garments e.g. No synthetic boxer shorts, and no under wires on bras. No synthetic attire and no jewellery to be worn by a competitor whilst completing.

BALACLAVAS: Comply with SFI 3.3 or FIA 8856-2000 and must be worn

BOOTS: Comply with SFI 3.3 or FIA 8856-2000

GLOVES: Comply with SFI 3.3 or FIA 8856-2000 and must NOT be modified in any way.

HELMET: Full faced and comply with the AS1698 standard and must be no older than 5 years from the manufacturer date. The higher Snell standard helmet can be used and is recommended. However, if helmet is misused, neglected, or damaged, it may be rejected and impounded by Machine Examiner or Technical Committee at any time, and if considered to be unsafe, scrutineers log book entry to be completed along with drivers log book and helmet cannot be used again for any speedway event. Chin cup on helmet not permitted. Spectacles, visor or sunglasses, when worn, must have lenses of non-splinterable material.

HORSE COLLAR: Compulsory if driver is not using a Head and Neck Restraint.

HEAD AND NECK RESTRAINT: Recommended but not mandatory. If worn a Head and Neck Restraint must conform with SFI 38.1. An AS1698 helmet must not be modified in any way. Only a SNELL SA-2005 or Snell SA-2010 helmet can be modified to wear a head and neck restraint device.

SEAT BELT: Five or six mounting point restraints are mandatory. Shoulder and Hip Belt width 50mm minimum. 75mm highly recommended.

SEAT BELT LIFE:- MAXIMUM OF FIVE YEARS FROM DATE OF MANUFACTURE

Only belts with over centre lever lock buckle to be used.

An approved type racing harness must be fitted, using a minimum of four major belts and four mounting points, plus one or two anti-submarine/crotch straps. Anchor bolts to be 10mm steel min.

Shoulder belts to have separate anchor points/adjusters.

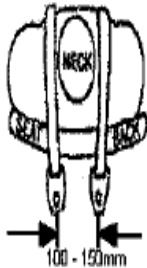

Fig 2 (i)

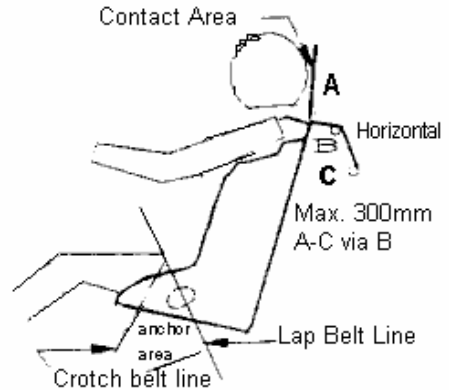

Fig 2 (ii)

Shoulder belt mounting points shall be positioned to the rear and below the point at which the shoulder belts come through the seat and be not more than 300mm from that point, attached to 38mm x 3mm tube. Fig 2 (ii)

Lower seat belt mounting brackets (anchor points) must be on roll cage and chassis or substantial bar work using a minimum construction of 25x25x3mm RHS or 25mm OD CHS.

Seat belt attachment tag to be 3mm minimum mild steel.

Fig 3 (i)

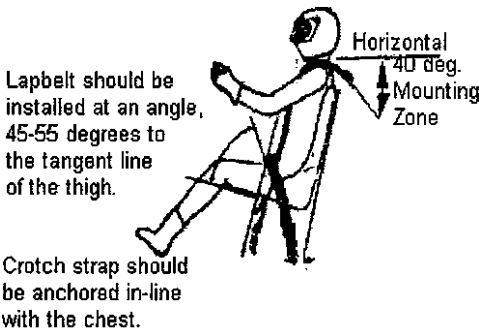

(ii)

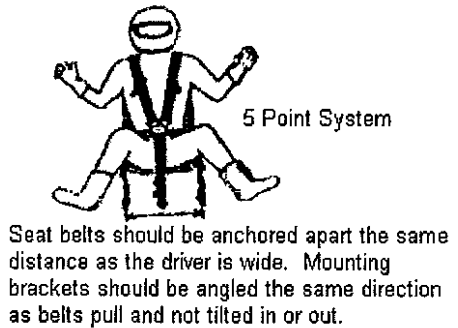

(iii)



Fig. 3

Shoulder harness should be anchored at a 45 degree angle from the seat. If mounted to a roll bar cross brace, located 100mm below the shoulder line.

(iv)

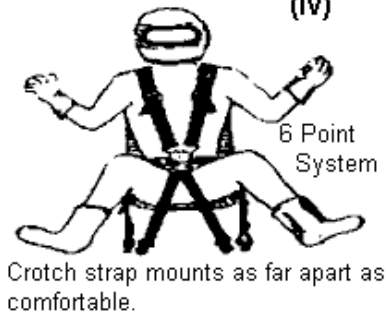

Fig 3 Sample Seat only shown for clarity.

See "Installation of Restraint System".

See "Adjustment of Driver Restraints".

INSTALLATION OF DRIVER RESTRAINT SYSTEMS: Fig 3

In order for the driver restraint system to be fully effective, considerable thought must be given to the location of mounting points, and to proper installation.

With the seat, roll cage and belt anchors all part of the same structure, deformation of the remainder of the car does not put driver at serious risk.

The mounting points must be solid and should remain so even if the vehicle is deformed due to an accident. The mounting points should also not put undue strain or twist on the belt system hardware.

The lap belt should be positioned so it rides across the solid pelvic area and not the soft stomach area or down on the thighs. The shock absorbing ability of the pelvic area and its ability to protect internal organs make it the preferred location for the lap belt. See Fig 3 (i) & (iii).

The shoulder harness should be mounted to prevent driver's shoulders from moving forward (upward if semi-reclining), out of the seat, in the event of a rollover.

The required minimum 50mm from the top of the driver's helmet to the roll cage roof/hoop bar does not leave much leeway for the shoulder harness to prevent the helmet from striking the head plate or bar work in the event of a rollover. The shoulder harness is a major means of preventing injury in such an incident.

Anti-submarine straps serve two purposes.

1. To secure the lap strap down across the driver's hips, so in the event of an accident, it is not pulled up across the stomach by the shoulder straps.
2. To prevent the driver from sliding forward and out of the harness. When the driver is seated in an upright position, as in most sedans, a five point system (a single anti-submarine or crotch strap) is considered adequate (Fig ii). For extra assurance a double strap anti-submarine belt can be used (Fig iv)

When the driver is seated in a semi-reclining position a six point system (two anti-submarine or crotch straps) is preferable. Most drivers find the two anti-submarine strap system more comfortable. In many instances, the anti-submarine straps are mounted much too far forward of the seat.

This practice could cause unnecessary injury as the body can slide partially out of the seat before being restrained when the strap contacts the groin. It is much more practical to cut a slot in the seat bottom so the anti-submarine strap can be anchored in line with the chest. (Fig i)

Because of the differences (often vast) in competition vehicles, a 'standard' method of mounting is impractical. Good judgment and common sense in inspecting restraint system mounts is needed.

Safety equipment is often neglected in favour of performance equipment, but its proper operation when the need arises is essential to survival.

ADJUSTMENT OF DRIVER RESTRAINTS:

With the driver fully kitted out in 'long johns and driving suit', check that, with the driver seated, belt slots in the seat line up with natural line of the belt from anchor to buckle when just the lap belt is tensioned. Ensure that the lap adjusters do not foul the seat and that they are readily accessible. Some belts adjust by pressure downward others by pull up.

Check that the driver can manipulate belt adjusters with gloves ON. Check also that anchor hardware is aligned and that it is not possible to have a hitch in the anchor area without detection (sudden release of the belts to 50mm slack can put the driver off-line). Now check if the belt is holding the seat or the driver, it should be the latter.

Adjust the anti-submarine strap/s to ensure that the buckle is held flat and close to

the body over the pelvis. When satisfied that the lap belt is OK, put on the helmet and check just how far the helmet (with visor) can reach, head plate clearance, helmet net etc.

Slacken the seat belt, engage the shoulder belts into the buckle and tension the seat belts again, checking position of the buckle and adjusters. Tension each shoulder belt, checking that the adjustment range is suitable to the driver, that the belts and hardware don't foul the seat and that the natural line of the belts holds the driver as with the lap belts. Note also any change in the buckle location and lay. If there is too much variation with the buckle it would appear that lap anchors are not in optimum position.

Before drivers releases the buckle he should slacken shoulder belts with the adjusters, keeping the area of the adjuster supple, accessible for cleaning and making entry to the car a simple routine.

While lining up for restarts, it becomes a simple exercise to tug the adjusters to snug up the belts and stay in control of the car.

WINDOW NET:

Window net is mandatory.

Net to be a minimum 19mm woven webbing with 75mm max hole size. See appendix A (or SSA Inc approved window net)

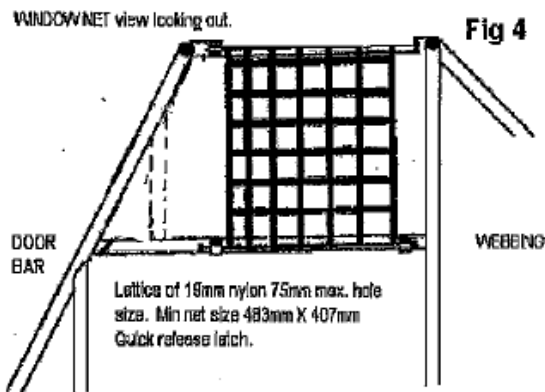

It is recommended that the window net be hinged from the bottom. Window net - A lattice of 19mm woven webbing. Rod thickness to be a minimum of 6mm.

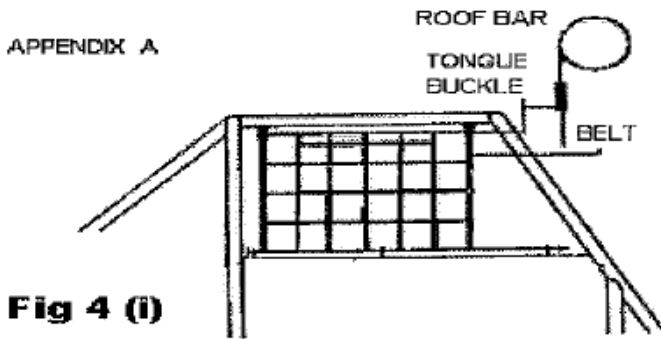
**Fig 4 (I)**

This design uses two push button seat belt buckles and belts. Tongues are welded to side of roof bar. 25 X 3mm FMS welded to rear of buckles. Tubing at base of net fixed with bonnet lock pins.

PADDING:

The driver must be protected, in the race car, from all sharp edges and projections or bar work, which could cause injury in an accident.

FIRE EXTINGUISHER:

On board fire extinguisher permitted. It must be securely mounted and be of the correct type for the fuel being used.

10. SEAT:

Minimum 50mm clearance helmet to roll cage roof/hoop bar.

- a) Seat to be mounted totally on the right hand side of the vehicle centre line measured at waist line of body.
 - (i) 4 DOOR CARS. No part of the seat may be more than 125mm behind the centre pillar.
 - (ii) 2 DOOR CARS. Must not be further back than rear of "B" pillar, both measured at window sill height
- b) Seat base to be mounted to roll cage chassis at a minimum of two points using 8mm bolts and minimum of 40mm diameter body washers. Four points recommended.
- c) Seat back to be braced to, and attached to, the roll cage approx 75mm below shoulder height using a minimum of two 8mm bolts and 40mm body washers.

- d) A "Purpose Built" one piece, solid (i.e. no lightening holes), fibreglass, steel or aluminium bucket type seat incorporating a substantial head rest must be used. Approved proprietary line competition seats and mounts permitted. Eg Kirkey, Butler, United Speedway Accessories, Bratpac and Racetech. The use of a full containment seat is recommended or at least the use of a seat with head and shoulder supports.
- e) Spring upholstered, Plastic, or magnesium alloy seats not permitted.
- f) Lateral (sideways) support must be given to hips and above waist. Concave seat to support back to minimum of TOP of shoulder height and width.

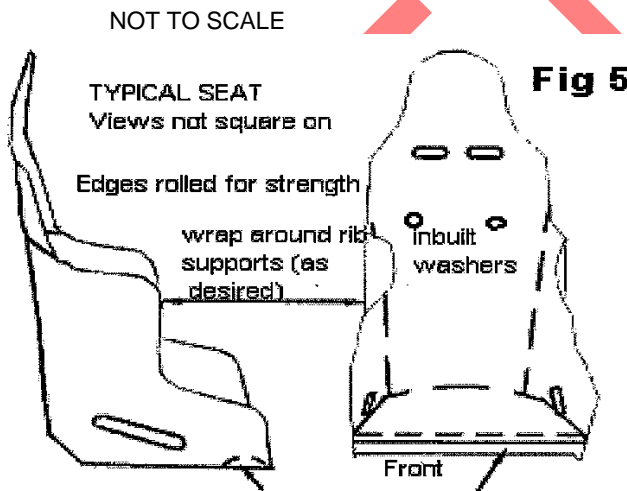

- g) Top of head rest to be at least 50mm above helmet contact point, head rest must be padded. At the discretion of the Scrutineer the head rest will need a form of support if it is deemed too flexible and/or the area between seat and roll cage is too great. Upper support (mounting bolts) should not exceed 75mm below shoulder height.
- h) Cut-outs for belts to be suitably grommetted and have adequate clearance.
- i) All seats may be padded and covered, the covering being securely attached. Maximum padding thickness 50mm.
- j) Driver to be able to reach pedals mounted in the original OEM mounting position.

CLASS SPECIFICATION

STREET STOCK

11. CLASS CRITERIA

- a) A Street Stock class car is built from a hard-top road car seating a minimum of four persons, as per the compliance plate, and catalogued for sale in Australia. ie. available new, to the general public, through authorised Dealer sales and service networks throughout Australia
- b) “Base model” body is used for silhouette and measurements. Forced induction models not permitted in that form.
- c) Four wheel drive and/or four wheel steer models not permitted.
- d) Passengers optional, but all bar work to be mirrored from right hand side. Passengers must face forward.

12. DIRECTION OF RACING

The direction of racing will be directed with the toss of a coin prior to each race, heads anticlockwise and tails clockwise from the pit gate.

13. STREET STOCK DERIVATION

- a) Race Car - To be of the base model of a series, as deemed by the manufacturer.
- b) Basic SPECS of CAR: Four or Six cylinder only, EXCLUDING Turbo/Supercharged, Four Wheel Drive (4WD) and/or Four Wheel Steer (4WS) models are not permitted.
- c) Age limit on Street Stock Eligibility – 5 years. For 2012 – competitor can only build up to 2007 model car.
- d) O.E.M. Original Equipment Manufacturer – means for make and model unless otherwise stated.

14. BODY

Transferring a roll cage from one body shell to another constitutes a new registration. However if it is currently registered and both the same make and model no fee is payable.

- a) MONO-construction sedan, coupe or hatchback vehicle ONLY.
- b) Full chassis cars or convertibles NOT permitted.
- c) Parts to be removed: All glass, interior trims, grille, door handles, ornamentation, Bull bar, tow-bar and helper springs. (glass apertures must not be covered with fibre glass or other material).

- d) The only panels which may be replaced with fiberglass / aluminum, metal / plastic replica: - max. 2mm. thick, are doors, bonnet, boot, front guards, nose, head and tail light apertures. If original roof is damaged, fiberglass overlay may be used over existing damaged roof. Under panel reinforcement plate not permitted. Replacement panels must be securely fastened, self drilling (TEK) screws not to be used.
- e) If replica panels used: - To assist with the fitting of door panels, maximum of 25mm x 25mm x 3mm RHS, may be welded at window sill height from A to C pillars.
- f) All body-work, including any subsequent repair of any race day damage, shall be to a Tradesman-like standard and must permit the vehicle to be presented in as near to original condition as possible.
- g) To assist with appearance of cars, the rear quarter panels may be COVERED with fibreglass replica panels securely attached to the steel panel. Self drilling (TEK) screws etc. or self tapping screws are not to be used. The inner boot skin side vertical panel may be removed.
- h) The door pillars may be notched for bar-work but otherwise must remain intact.
- i) Doors to be securely bolted or welded.
- j) Only interior parts which may be removed:- Dash Panel - to assist with the roll cage installation. Replacement dash panel is not permitted to continue past the forward most point of the steering wheel across the width of the car. No extra decking or internal sheeting permitted in cabin. If the rear radiator mounts against the rear firewall, the core area of the rear firewall may be removed.
- k) Data logging dashes are not permitted.

Fig 6

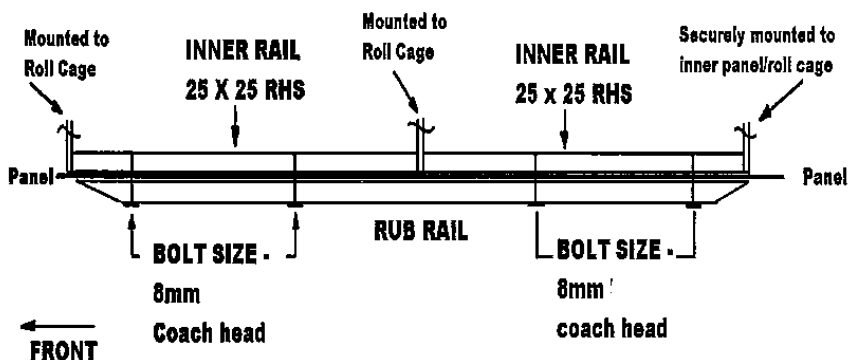

- l) Mild Steel rubbing strip between wheel arches 25X25X3mm MS RHS or alternately a nylon (urethane, nolathane) rubbing strip 50mm x 12mm thick. To be securely mounted against body, at a minimum of four points, evenly spaced. Bolts must be minimum 8mm coach head (cuphead) and be bolted horizontally to barwork. Bolts at each end must be no more than 50mm

from the end of rub rail. Inner mounting bar 25 x 25 x 3mm or roll cage material to be returned to the chassis or roll cage at each end. Rubbing rail ends to be closed and taper to 45 degrees as not to become a 'spear'. Fig. 6 Rub strips not to be used on quarter panel behind rear wheel.

- m) Rear View mirror - not permitted
- n) Ballast of any description is not to be carried. e.g. Water in tyres etc.
- o) Grille - If grille is fabricated it must be of a steel welded wire mesh, no thicker than 5mm diameter x 25mm minimum aperture or panel steel, 1.6mm maximum. Folded sections, for strength, are not permitted
- p) Light apertures must be filled using max. 1.6mm metal sheet, fibreglass or plastic
- q) Wheel arches - may be cut out to give a maximum of 50mm clearance around tyres. The inner and the outer panels of the wheel arch are to be re-welded.
- r) Bonnet - Bonnet to be securely fastened. Four bonnet pins (five for fibreglass) to be 12mm minimum to 15mm maximum mild steel or approved equivalent. Bonnet pins to be in the bonnet not sides of mudguards. No mounting pins in side of panels, i.e., mud guards. Bonnet lock pins 3mm min to 6mm max. Heavy duty large reinforcing washers (min 30mm O.D.) to be fitted to all bonnet pin holes on fibreglass bonnet. Similarly, boot lid to be securely fitted, using pins and large washers as for bonnet. The removable boot lid to be securely mounted in four points.
- s) Hinged bonnet and boot lid permitted, using minimum of two pins. Skeletonising not permitted on hinged panels within 50mm of hinges. The hinged panel to be welded to the bonnet or boot skin.
- t) Bumpers: ORIGINAL front and rear bumpers to be attached to sub-frame of vehicle using original mounting brackets or back to the roll cage, using one pipe per side. Where an original type bumper is not available, a bumper of similar profile and weight must be used. Plastic Bumpers to be retained, may be attached using maximum 40mm x 3mm flat aluminium and cup head bolts.
OEM steel bumpers permitted. All bumpers may have a pipe bumper, max 38mm x 3mm CHS to be securely mounted in original position using supports of a minimum of 100mm from rear of bumper tube max support size 38mm x 3mm CHS, 40mm x 40mm x 3.2mm RHS or 50mm x 25mm x 3.2mm RHS only. ie gussets are not to be used.

Front or rear original plastic bumper can be reinforced with pipe bumper. Front bumper maximum return 300mm minimum 100mm x maximum 38mm x 3mm CHS. Front spreader bar between bumper bar mounts permitted, as per figure 7(i). Front and rear bumper to be covered with a plastic road car bumper. Bumpers are to remain hollow. Corners and ends of front and rear bumpers to be radius formed 100mm maximum. Maximum of four mounting points on each bumper. Returns and bumpers to be flush fitting with the body within 25mm. anti hook up bars from returns of front

and rear bumpers to be extended to the chassis rails. Non OEM bumper skirts not permitted.

Rear only: returns of rear bumper may extend as a skid rail against the outside of the body between bumper and wheel arch and then extend inward to the chassis rails. Corner plates on top edges of either bumper not permitted.

Pipe bumpers are to be mounted to original bumper mounts using maximum 3mm flat plate and may extend inside chassis rail maximum 250mm. Bumper to be returned to chassis and bolted or welded to side of chassis rail using maximum 250mm x 3mm flat plate. Alternatively front and rear bumpers maybe attached to the roll cage (one bar per side maximum 38mm x 3mm CHS). If this option is used roll cage rearward brace bars may attach to this CHS.

Fig 7

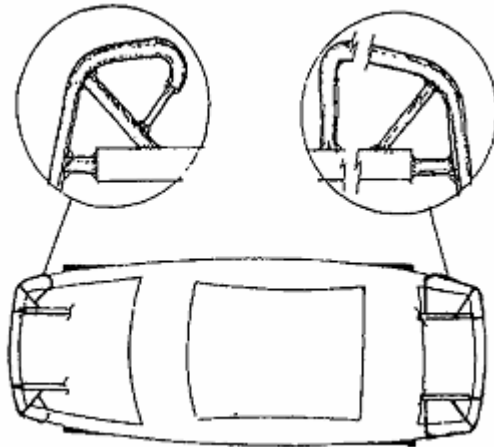
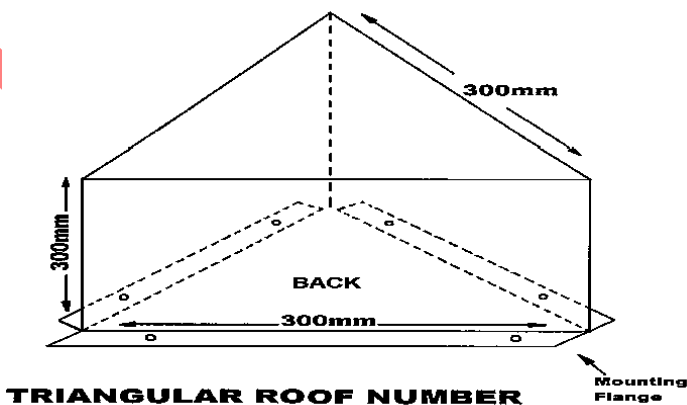

Fig 7(i) Bumper-to-Bumper Kit



- u) **Paint-work and Sign-writing:** All paint-work, sign-writing and numbers to be neat, attractive and of a professional standard. Fuel Tap - to be clearly marked, indicating FUEL and the positions ON/OFF. Engine Kill Switch - to be clearly and suitably marked with a contrasting colour, and must be fitted in the centre of the cowl panel.
- v) All vehicles must carry the identification number, as issued by their club. This number may be displayed on each side of car and on the roof. Numbers are to be a minimum 460mm high x 75mm line width minimum and in contrasting colour. (For lap scorer). Club prefix, if required, 150mm high and to precede number. Identification number to be visible from front of car (for pit Marshall). The name of the driver will appear on the roof over RH door or on visor strip, in letters of a minimum of 75mm high.
- w) **ADDITIONAL FIREWALLS**
The driver must be protected and isolated from mechanical, fuel, electrical, including battery, and exhaust components by metal fire-walls, min. 1mm. thick.
- x) **Roof Plate.**
The use of a roof plate number is mandatory for all race meetings, State and National titles.
It shall be a metal plate, 30cm square with a 5 cm right angle fold at the bottom, where 2 holes, at 20cm centres shall be drilled to take 6mm bolts. The number on the plate shall be painted using a black background & white number/s. Number to be minimum 250mm high in block font. A triangular 3 sided roof number is optional. Plate to be 300mm x 300mm x 300mm. Black background with white number. Fig 8.

Fig 8



15. ROLL CAGE

All new cars must be fitted with a complete Roll Cage built to the NASCAR design as used in other classes within SSA Inc. Refer also Fig 9(i-v)

- a) The roll cage is to prevent the collapse of the cabin area under impact. Roll cage, to enclose the driver, to be full width and full height of the cabin area and will be within 50mm of the inside line of the B pillar, measured at window sill height, parallel to the window sill line. Self drilling (teck) screws etc. or self tapping screws are not permitted to be used and no pop rivets
- b) The roll bars are to constitute a cage type framework, braced fore and aft.
- c) The cage must extend from behind the driver's seat forward to the windscreen area and incorporate protection for the driver's feet. All roll-cage bar-work is to be inside the body.
- d) All roll bar material must be of a good quality mild steel, minimum AS1163 Gr300. MINIMUM 38mm OD x 3.0mm wt. CHS. (Sonic tester reading, at not less than 2.70mm ABSOLUTE). Aluminium based materials not permitted.
- e) All bends to be made using a pipe bender with the correct size former. Galvanised tubing or welding over threaded tubing not permitted in any structural bar work. Water pipe fittings or malleable fittings are not permitted.
- f) Roll cages built using other than fusion welding techniques will not be accepted. Gussets on welded joints may be required (Daylight Inspection).
- g) The rear main hoop and the main roll cage bars will each be made of one continuous length of tubing, with smooth continuous bends and no evidence of crimping, wall failure or significant weakening. (Fig. 9(v)).
- h) Main roll cage hoop to be within 50mm of sides of roof at narrowest point. Top windscreen bar to be within 50mm of windscreen at front roll cage leg on side elevation. The base of the main roll cage hoop to be fitted square in the car.
- i) **Roll Cage legs**
Roll cage legs - to be welded to top of a sub-frame of tubular or angle section running fore and aft. The sub-frame is to be securely welded or bolted to the floor pans/sills using at least four 12mm steel bolts through the sub-frame and using 100mm x 100mm x 3mm minimum plates under the floor, or bolted on the spreader bar no more than 150mm from sub-frame.
- j) To assist in the fitting of roll-cage bars in the dash area, the dash panel may be removed.
- k) The front roll-cage legs are to follow the "A" pillar line. Exception: Cars with severe rake of the windscreen. Angle of roll cage "A" pillar bar to be of not less than 45 degrees down from roof bar. (fig. 9(ii)) Quarter window bar be installed from the top NASCAR bar to top half of pillar bar using minimum 25mm x 3mm CHS (38mm x 3mm CHS recommended) Alternately, a

38mm x 3mm O.D. bar may be fitted from top of "A" pillar bar to top of NASCAR bar at 45 degrees of the top bar both sides. Fig 9(ii). If a pillar bar does not follow "A" pillar line and is 45 degrees, additional sub frame cross brace from front of foot protection to LHS is required.

Fig 9 (i)

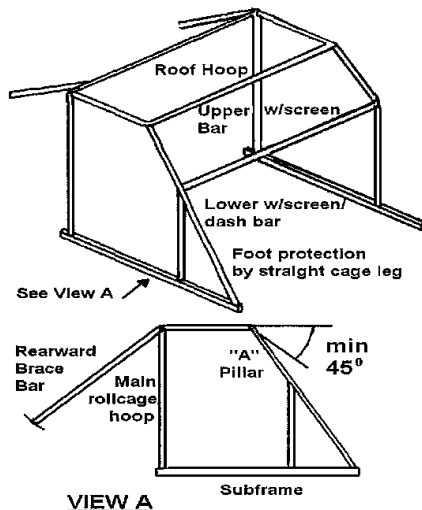
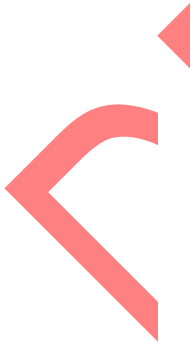
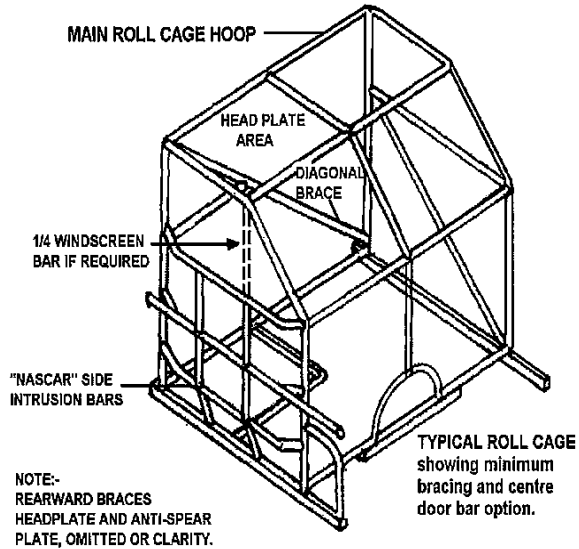
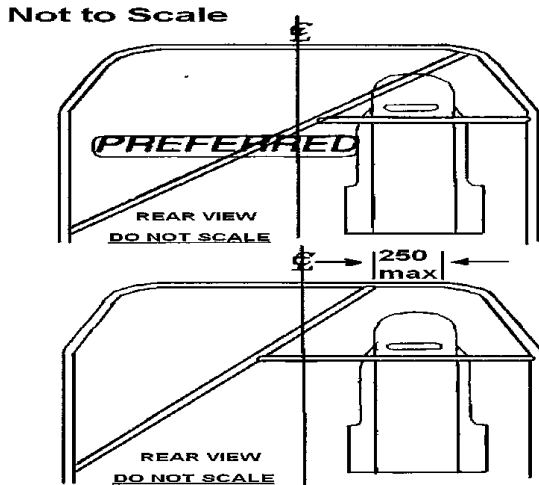

Fig 9 (ii)

Fig 9 (iii)



Sub-frame Material Sizes

- (i) Tubular min. 38mm x 3.0mm wt. CHS
or 50mm x 50mm x 3mm wt. RHS
 - (ii) Angle minimum 50mm x 50mm x 5mm.
- m) A one piece diagonal brace, min. 38mm OD x 3.0mm wt. CHS., will be fitted in the main roll cage hoop behind the driver's head, within 250mm of the corner and down onto the left side roll cage leg. (Top right to Bottom left) Fig 9 (iii).
A second brace may be fitted in cruciform for passenger option. The diagonal brace, top right to bottom left, must be one piece. If a cruciform type bracing is used a minimum of 32mm OD x 3.0mm wt. CHS. may be used.
- n) **ADDITIONAL MINIMUM BARWORK**
Material size - 38mm OD x 3.0mm wt. CHS.
Top windscreen bar.
Lower windscreen / dash bar.
Seat back support/Shoulder belt mounting bar.
- (i) Nascar Door Bars
On the driver's (right) side - three horizontal side bars, curved out to the door skin, are to be placed between the front and the rear cage legs, evenly spaced between the window sill and the roll-cage

sub-frame. On the driver's side nascar bars, one of the three horizontal door bars may run straight through, eg from front wheel arch to rear wheel arch and then have two separate pieces of 38mm x 3mm turning at ninety degrees to the nascar bar connecting on to the roll cage a and b pillar bars

A minimum of two vertical spacer bars, evenly spaced between the front and rear roll cage legs, are to be fitted within each opening between the cage sub-frame and the top horizontal bar a minimum of six bars fitted. The top horizontal NASCAR bar will be within 50mm of the window sill ("NASCAR" bars in Fig 9(i))

(Left) side: Two bars fitted between the front and the rear roll cage legs. One must be horizontal within 50mm at window sill height.

The top drivers side nascar bar, lower windscreen bar and passenger's side nascar bar maybe formed in one continuous bar. This entails the "A" pillar bar to be formed in two pieces.

- (ii) Cross Brace/spreader bar - A minimum of two sub-frame cross braces within 200mm of roll-cage legs. A brace is required if more than 200mm and these may be , either 38mm OD x 3mm wt. CHS or 35mm x 35mm x 3mm wt. RHS. Spreader bar may be covered with metal sheeting in drivers foot well area only..
 - (iii) A quarter window bar, if required because of excessive rake or a long roll cage, be fitted to both sides and installed from the top NASCAR bar to top half of pillar bar using minimum 25x3mm CHS (Recommended 38mm x 3mm CHS).
 - (iv) Centre roof bar, 32mm OD x 3.0mm wt. CHS
 - (v) Centre windscreen bar, 25mm OD x 3.0mm wt. CHS
 - (vi) Rearward brace bars from the top rear of main hoop down onto rear sub frame (approx 45 degrees), no closer to the rear boot panel than 300mm. May be crucifix. Must attach to the rearward side of the hoop within 100mm of the centre of the top radius, To be minimum of 34mm CHS. May have one spreader bar as long as it is of pipe material. Minimum 34mm x 3mm. Rearward brace bars may be bolted together within 200mm of roll cage hoop. Bumper support bars maybe bolted within 200mm of roll cage spreader bar.
- o) Mesh screen, in front of the driver, will be securely fitted to the roll cage/body. Maximum mesh size 50mm x 50mm. Minimum size 3mm. Mesh screen to cover entire area from "A" pillar to center bar and from dash to roof bar. Windscreen mesh to be welded, or clamped with metal clamps to the roll cage "A" pillar and centre windscreen bar. Minimum of four clamps. May be welded to body.
 - p) Front strut towers may be braced back to lower windscreen bar using one bar per tower. Brace bar may extend forward down to chassis rails or lower optional bar work. CHS 34mm x 3mm wt Maximum, with a 3mm x 100mm x 100mm plate welded to tower for support.
 - q) One piece anti spear external door plate 3mm steel or 5mm alloy, (NOT to

be lightened by drilling) to be fitted on driver's side, on the outside of the nascar bars, from floor-line to window sill bar, forward of the first vertical door bar to the front leg of roll cage. To use a minimum of 6 - 50mm x 50mm x 3mm MS tags and bolted to either 8mm or 5/16th high tensile bolts with no protrusions. If individual pieces are used then a minimum of four 50 x 50mm x 3mm MS tags and bolted to either 8mm or 5/16th high tensile bolts to each piece with no protrusions.

- r) Minimum requirement for foot protection be a minimum of roll cage material. Foot protection bar and brace bar is mandatory if drivers feet are past the A pillar bar whilst the driver is seated in the car in race position. A bar min 25x3mm support from the foot protection bar must be attached to the foot protector bar at one end and the other end to bar work to the left. A plate may also be required. Fig. 9(iv)
- s) **Passenger Option:** - Roll cage left side must mirror right hand side and have full cruciform. Passenger handle for support, optional.

Fig 9 (iv)&(v) Roll Cage alternative (for existing cars only)

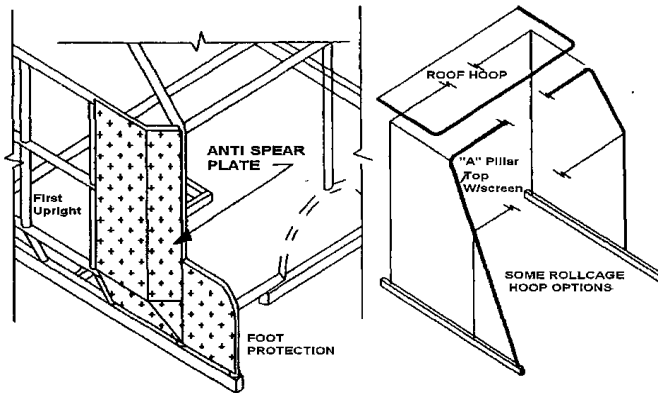

Fig 9 (iv)

Fig (v)

16. HEAD PLATE

To simplify the removal of an injured driver it is highly recommended that a removable full size head plate be used. Fig 10.

- a) Head Plate to be of 5mm ALUMINIUM ALLOY or 3mm STEEL 25mm x 3mm FMS strip to be welded to main hoop, top windscreen bar, centre roof bar and side roof bar. 10 of 50mm x 50mm x 3mm MS tags acceptable.
- b) Plate to be mounted, from above, with 10 x 8mm (5/16") diameter. High Tensile bolts, 3 each side, 2 front, 2 rear. Heads of bolts to be downwards and spot welded, e.g. no protrusions.

Fig 10

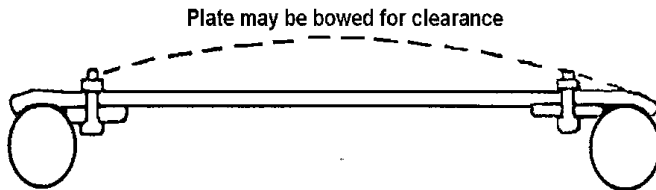

ALTERNATIVELY

- c) A head plate min 3mm steel must extend from rear roll bar to top windscreen bar and from driver's side outer roof bar to centre roof bar. This plate must be securely welded to these bars with intermittent welding procedure.
- d) Helmet clearance between roll cage roof/hoop bars for existing vehicles, may raise head plate as per drawing below, to obtain 50mm clearance. Fig 10 (i)

Fig 10(i)

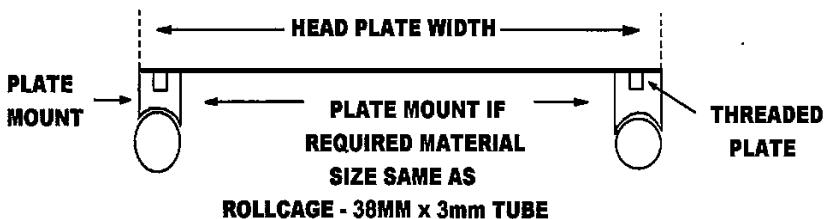

- e) Mounting procedure for raising of head plate (existing cars). 10 stubs 38mm x 3mm tube – stub length is determined by height required to gain 50mm clearance.
- f) Stubs to be end capped and threaded for mounting purposes.

17. ENGINE AND AUXILIARY EQUIPMENT

ENGINE SEALING IS COMPULSORY

Engine identification tag for Street Stock Class will be Red.

Engine Seals will be placed – 2 x Sump and or timing cover 1x Cylinder Head.

All Engines must have a number/s or letter/s stamped on the block E.g. 3 x engines, 3 different engine numbers.

SSA use triplicate copy engine sealing books that are numbered, one copy to car/engine owner, 2nd copy for engine sealer, original to state office.

Car owner/driver to have copy of engine sealing form with logbook at all times.

- a) In the engine bay one should see the basic items as in the road car, e.g. ignition, coil and distributor, fuel pump, air cleaner, radiator and charging system, all in use on the engine.
- b) ENGINE to be FOUR or SIX cylinder reciprocating ONLY. Rotary, turbo or supercharged engines and not permitted. Mechanical fuel Injection systems are not permitted.
- c) Late Model Cars may fit earlier engine or engine for model E.g. EA Falcon onwards may use 4.1 alloy cross flow engine or 4lt EFI engine. VN Commodore onwards may use Holden 6 cylinder in-line engine or V6 EFI engine. The engine must be positioned in the engine bay with the rear face of the block in the same position as the original engine for the model. Specification used for these engines will be based on engine model being used. No engines after AU or VY to be used. Others not included above must be approved by National Technical Committee prior to construction.
Ecotec engines in VE Commodore to use an SSA approved sump.
(eg. Castlemaine Rod Shop sump)
Engine approved for V6 Magna 6G74 3.5lt multivalve single cam per head. Must use approved Falcon computer and airflow meter may be replaced with Falcon map sensor to suit computer. Variable cam timing not permitted.
- d) Engine to be the type and size for the model (see Engine List) except VN Commodore and EA Falcon onwards. Any doubts about engine sizes etc. will revert back to manufacturer's "base model" of the registered series.
- e) Engines will be inspected on the basis that all parts used in/on all engines must comply with the specifications/dimensions specified in the original (O.E.M.) manual produced by the manufacturer for the standard engine; with the exception of the listed permitted modifications. The owner/driver is responsible to prove the above and produce information when necessary to validate the claim.
- f) Refer, Australian Standards "AS 4182-1994 Code of practice for Engine Reconditioning Standards". Engine Balancing: The balancing of any engine componentry or removal of any balance shaft in this class is STRICTLY PROHIBITED. The only tolerance allowed, are the drill holes in the crankshaft

as done by the manufacturer (OEM). The conrods cannot have any metal removed or polished. The pistons cannot be machined or lightened.

- g) A standard engine is allowed no more than .060" overbore and .060" for head facing.
- h) Engine Block: The maximum allowable cylinder sleeves to be fitted to an engine block to be two in total.
- i) OFFSET boring of bearings &/or cylinders, offset grinding of crankshaft or angled facing of head to block surfaces are not permitted.
- j) Engine to be of standard stroke, con-rods and crankshaft to remain as OEM parts for the engine model; the fitting of other model, make or specially built cranks &/or rods not permitted;(standard replacement ARP conrod bolts are acceptable) port sizes and casting finish as for base model.
(Eg) 4.1ci Falcon must use 4.1 conrods & crankshaft, Holden blue/black engine must use counter balance crankshaft, not red engine crank shaft.
The use of performance aftermarket harmonic balancers (ie Power bond Street Performance) and head studs to replace head bolts is not permitted.
Complete harmonic balancer to remain standard for model of engine.
All pulleys other than harmonic balancers have no restriction on size.
(ie) power steering, water pump and alternators.
Intake manifold/plenum chamber to remain OEM standard, this means no machining, no welding, no extra vacuum ports, or drilling for sensors.
All 4lt Falcon engines may use any OEM head up to and including AU, but valve size to be correct for model of engine.
- k) Standard flywheel (not lightened). Holden 3.3 blue/black engine must use that flywheel, not 3.3 red engine flywheel.
Minimum allowable thickness – Falcon 20.5mm, Holden 32mm, Valiant 22mm, GN Sigma 22mm, GH Sigma 34mm. Must use original cast flywheel with original markings. Except V6 Commodore may use an aftermarket steel flywheel. Allowable minimum thickness of 35.5mm (not lightened).
- l) CAMSHAFT and camshaft timing parts are not restricted. Camshaft lifters to be solid or hydraulic. The use of adjustable lifters is permitted.
- m) The use of performance parts in the valve train is prohibited, e.g. Roller rockers, cam followers etc.
- n) Engine sump to be visually standard externally
- o) Oil Coolers, if used, are not to be mounted in the cabin area. Engine oil coolers to be OEM only.
- p) Slow rotor caps fitted to exhaust valves inline six cylinder Commodore may be replaced with spring and cap from inlet valve. The use of valve spring dampers permitted.
- q) If resilient engine mounts are used, a wire cable or chain restraint must be fitted.

18. ENGINE – ELECTRONIC FUEL INJECTION:

SSA reserves the right to exchange sealed and tested computer supplied from Automotive Service Solutions at any time during a race meeting.

1. E.F.I. is permitted to use the following restrictions.
 - a) SSA Inc. approved and sealed ECU. All computers are to be sealed by Automotive Service Solutions only.
 - b) Engines to be limited up to VY Commodore Ecotec and up to AU Falcon, no variable cam timing (VCT). All Commodore engines after VP are to use VN / VP computer, DFI module and coil packs. Standard memcal only to be used. All Falcon engines after EB to use EA/EB computer and may use inlet manifold and injectors for model of engine, or EB manifold and injectors. No High output or Tickford heads allowed. The original casting number on the front of the head must remain. EL not to use AU engine.
 - c) Standard exhaust pipe size; must be fitted to beyond rear of drivers seat, then free from there.
 - d) All standard sensors must be fitted and be operating including fuel pressure regulator except oxygen sensor and coolant sensor.
 - e) All engine components must be fitted (air cleaners etc)
 - f) Engine specifications as in all other engines.
 - g) Header tanks for fuel pumps not allowed.
 - h) No adjustable fuel pressure regulators
 - i) Rev limiter to remain OEM
2. The following are specific items relating ONLY to models produced with OEM Fuel injection:-
 - a) Standard size OEM injectors are to be used for make and model of engine or fuel injection system used. Inside diameter not to be increased or decreased.
 - b) Petroleum, no additives, maximum specific gravity .780, maximum octane 98. Must be supplied by a commercial outlet, through a multi volume network via bowser pump by Shell, Caltex, Mobil or BP only. Fuel may be tested by any means available.
 - c) Any passenger car fuel pumps only are permitted. Fuel pump must be fitted with engine monitoring relay to stop fuel pump running when engine stops. Fuel pumps to be mounted in the boot area.
 - d) A flexible fuel line section must be fitted within 75mm of fuel tank and all fuel lines to be securely fixed in position.
 - e) Barbed fitting of the correct size must be used in conjunction with screw type clamps when connecting flexible fuel line. (Genuine SAE R6 fittings and hose exempt)
 - f) Neoprene, reinforced plastic or "black fuel line" may be used. OEM type bundy steel tubing may be used through the car or under the car.

- g) Flexible fuel line can pass through the cabin area, must be one piece.
- h) High pressure lines are to use high pressure hose and fittings.
- i) If a return line is used, it must be fitted with a one way valve, at the fuel tank.
- j) Computer control units are restricted. If OEM unit includes ignition, must perform this function.
- k) Size of throttle body to be OEM type and size for model being used and to be standard in INTERNAL and external appearance. (No machining or alteration permitted)
- l) Checks will be on fuel and OEM equipment. Any modification to throttle body or butterfly is not permitted.
- m) Radio telemetry to or from a car to cars will not be permitted.
- n) Non OEM fuel injection not permitted. Forced induction not permitted.
- o) Return springs must be fitted to each butterfly shaft (inbuilt springs accepted),
- p) Protective wire gauze or air cleaner to be fitted over air intake to prevent entry of foreign objects to throttle body and also to act as a flame trap. OEM Air filter and airflow meter may be in cabin or moved under the bonnet. Air filter inlet to be shrouded from driver. Must be under bonnet if passenger in the car.
- q) ADDITIVES The introduction into the combustion chamber/s of additives, either in solid, liquid or gaseous form, (eg. nitrous oxide) by any means is expressly forbidden.

THE ABOVE ITEMS ARE SUBJECT TO REVIEW AT ANY TIME.

19. CARBURETTOR

- a) DEFINITELY not more than one carburetor as originally fitted.
- b) Refer Carburetor Listing in Rear of Manual or use one only 1⁷/₃₂" Stromberg carburetor with 25mm maximum adaptor.
- c) For all cars the carburetor is to be: OEM standard or Stromberg option, including venturi size, except that an adjustable main jet may be used; the choke butterfly and shaft must be in-place; float bowl position relative to engine, as in original vehicle.
- d) That any use of upper Cylinder lubricant via carburetor or vacuum system is illegal. Any vehicle found with these types of systems will be deemed illegal.
- e) A return spring MUST be fitted to each throttle shaft of the carburetor. (In-built springs acceptable).
- f) Air cleaner is to be of a passenger car type not a sports option. A pod type air filter in front of the standard air filter is accepted, but the standard filter must remain.

20. ELECTRICAL

- a) Battery to be securely mounted in a box or steel frame secured to roll cage or bar-work. All batteries and terminals to be covered with non conductive cover if battery is in cabin area to prevent spillage. Batteries mounted within the cabin area be held down by an angle iron/steel/aluminium frame (ie 25mm x 25mm) both top and bottom with minimum 8mm bolts or rods.

- b) The use of any battery over the size of N70ZZ is not allowed
- c) Suitable grommets must be fitted where electrical cables pass through metal fire-walls.
- d) At the commencement of a meeting car must be capable of starting with starter motor.
- e) Switches: Ignition switch and electrical fuel pump switch, if fitted, must be grouped together and be clearly marked.
- f) An engine "KILL" switch, suitably marked with a contrasting colour, must be fitted in the centre of "cowl panel".
- g) Electrical switches NOT to be mounted through the floor.
- h) Electrical wiring not to be attached to fuel lines.
- i) Auxiliary Equipment: e.g. charging system etc., to be as per base model.
- j) All electric fuel pumps to be controlled by an engine monitoring relay, to stop fuel pump running when engine stops.

21. EXHAUST SYSTEM

- a) Exhaust Manifold - to be "base model" standard, remainder of the exhaust system is free provided that it has not more than one outlet pipe, it is vented to the side or the rear of the vehicle behind the driver, and does not protrude beyond the body line.
- b) Internally ducted exhaust system if used shall vent through the body not higher than 100mm above the door sill panel, and to finish flush with the door panel.
- c) Driver to be suitably insulated from exhaust system. Insulation and firewall sheeting not to exceed 150mm above the drive shaft tunnel. Sheeting to cover exhaust to be within 50mm of exhaust, no other extra sheeting allowed in cabin area.
- d) If exhaust system is under floor, safety chains will be fitted to the front and the rear of the exhaust pipes and attached securely to the floor pan or sub-frame.
- e) The muffler/s must be securely attached to the vehicle.
- f) NOISE must be within the local requirements, recommended max. 95 D.B.A.
- g) EFI cars to run standard size exhaust pipe; must be fitted beyond rear of driver's seat, then free from there.

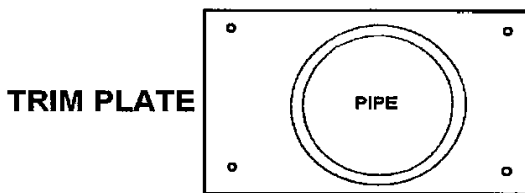

Panel flexes but pipe does not protrude

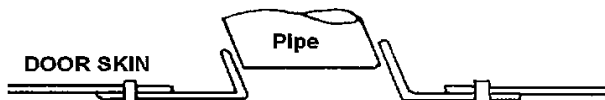

Fig 11

22. COOLING SYSTEM

- a) Front Radiator, if used, to remain in original position. Different type passenger car radiator may be used as long as it is in the same position as original, (fitted in same hole without enlargement) and does not protrude through the body work.
- b) Welded steel protection mesh of 25mm minimum aperture and 5mm maximum thickness may be used on both sides of the radiator. Mesh area to be not larger than radiator area.
- c) Rear radiator to be rearward of roll cage main hoop mounted in the rear cabin area but the top section of the radiator must not obstruct vision through the upper half of the rear window. If radiator is mounted against rear firewall, it shall be against the firewall in total with the core forming part of the firewall.
- d) Cooling system to have a manual pressure relief not push-button. Tap to be fitted with a hose to direct stream to the ground.
- e) Radiator can be converted to cross flow or vice versa. Cabin mounted radiators must have the tanks and cap totally covered to protect driver.
- f) The cabin mounted radiator is not to be shrouded to direct air into the radiator nor can the boot area be vented to let air out.
- g) Rear radiator coolant pipes through the cabin area are to be on the inside of the roll cage and to be lagged or suitably covered. Hoses are to be kept as short as possible and to connect to the radiator from the rear. All header tanks, hoses and caps in cabin area to be covered, and must be mounted below half window height.
- h) Pressure relief taps or caps to be fitted to both radiators
- i) Cabin mounted cooling fans are to be fitted with guards.
- j) Sprinkler bar or any such like device used for the provision of cold water onto the exterior of the radiator - NOT permitted.
- k) Engine Fan – Optional
- l) Electric Fans permitted.

23. TRANSMISSION

- a) Ratios are optional but must be from the same make or optional model.
- b) Gearbox to be Holden in Holden and Ford in Ford.
- c) Clutch Assembly to be of the standard replacement for the model gearbox being used.
- d) Scatter-shield: min. 3mm steel or 5mm alloy must cover upper 180 degrees of bell housing and be securely attached to protect the driver's feet and legs from a clutch explosion.
- e) Aftermarket bell housings permitted.
- f) Tail Shaft Loops - Steel strap minimum. 40mm x 5mm or 6mm chain or 6mm wire rope to be SECURELY fitted around the front and the rear of the tail-shaft within 150mm of universal joints to prevent the tail-shaft and or shafts from dropping in an event of breakage.

- g) Conversion of two piece tail-shaft to one piece and vice versa is permitted. (Additional tail-shaft hoops required for two piece.)
- h) REAR AXLE BEARING RETAINING RINGS: If using a rear axle assembly not fitted with floating axles, a new retaining ring must be fitted at replacement of bearing or axle. Ring must be an interference fit with the axle. When in place the retaining ring is to be tack welded to the axle using small diameter low hydrogen rod on low amperage or MIG welded. Failure to observe this procedure will incur a penalty, especially if an axle is dislodged. (Safety Declaration) Where a particular axle has a proven failure record, conversion to a stronger axle may be required.
- i) Differential - Must be locked. Ratios may be altered if the crown wheel and pinion only are changed. Housing to be from original model, not a complete differential from another model. Differential pinion angle to remain O.E.M., standard for make and model. The use of either of the top two differential mounting positions maybe used in EL or AU Falcon. Cast iron diff hats, mass produced are permitted.

24. SUSPENSION / STEERING

- a) A Street Stock race car must use a complete metal body with suspension mounting points in original position and being used.
- b) Suspension mounting points are defined as mounting points of suspension arm either end, shock absorber, either end, strut either end and springs either end.
- c) The use of jacking or other adjustments not permitted.
- d) Shock Absorbers/Strut Inserts:
Standard sealed replacement units only. No external adjustment/adjusters, e.g. no external reservoir/canister type, or externally gas pressure adjustment, (e.g. increase/decrease gas pressure). No competition aftermarket derivatives. E.g. AFCO, Pro. Mounting ends to remain original.
During the life of this manual, a controlled shock absorber may be implemented.
- e) Measuring of coil springs: Spring coil outer diameter to be the same as original spring. Maximum coil spring wire diameter – 18mm.
- f) Suspension- To remain visually standard with the exception of the strengthening of lower control arms by the use of 1 only 300mm x 12mm solid rod, stitch welded along each side of control arm. Standard size anti-roll bars if used must be fitted in original positions. Adjustable suspension arms, pannard rod/watts linkage's etc. are not to be used. Independent rear suspension is acceptable if optional for the model.
- g) Steering- must be standard. Modifications not permitted except for the replacement of LC/LJ rack with LH/LX rack. (Originals not available)
- h) Pedal position must remain in original position. The use of an AU Falcon pedal box, mounted in original position, may be used in a BA Falcon, due to the unavailability of manual pedal box.

- i) Original steering shaft/column- must pass through a loop of 12mm diameter. Steel rod welded or bolted to the roll-cage dash bar. Self aligning bearing may be used.
- j) Power steering optional – power steering racks and boxes to be O.E.M and in original position.
- k) Hoses and mounting position of pump is optional. Pulleys are optional. Power steering reservoir maybe fabricated to be a maximum 800ml, and coolers recommended. Mechanical belt driven pumps only. All power steering components to remain under the bonnet eg. hoses, reservoirs and coolers.
- l) The standard diameter steering wheel for the model must be used. Centre of the steering wheel to be padded. Removable steering wheel permitted.
- m) Steering from lock to lock to remain O.E.M. for make and model
- n) Strut brace between the towers permitted.

25. WHEELS / TYRES

- a) Maximum rim width 168mm. All wheels must be steel or alloy construction.
- b) Maximum rim diameter 15" for all cars. EXCEPTION cars with minimum 16" diameter OEM rims e.g. BA Falcon 16" permitted.
- c) Alloy or Mag Wheels may be used, but must be of one piece construction.
- d) Composite type wheels NOT acceptable. Composite wheel means wheels made of different materials. E.g. 3 piece alloy wheels are not classed as composite wheels. The use of wheel spacers not permitted
- e) Wheel studs must not protrude further than 12mm past the outer face of the wheel nut. Correct matching nuts must be used.
- f) Custom made offset wheels NOT permitted.
- g) TRACK to remain STANDARD plus or minus 15mm. (see list Page 35)
- h) TYRES: Radials only; 215mm side wall markings maximum; minimum 60 profile; speed rating H maximum; All details are to be visible in OEM markings on tyre side-wall. (e.g. 215/60 R15H or 215/75 R15H) The use of tyres branded "Competition Use Only" are not permitted
- i) Current use of retread tyres must have the correct remoulder's speed rating etc. and be legible as per AS 1973 – 1985 . V rated retreads permitted.

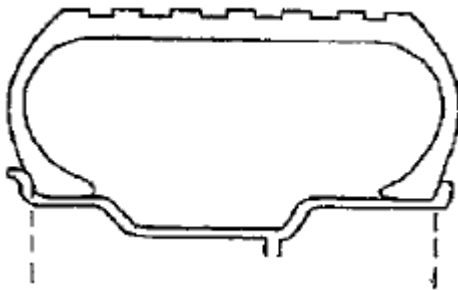

Fig 12

26. BRAKES

- a) Foot operated O.E.M hydraulic brake system to remain standard and to operate correctly on all 4 wheels and be effective at race speed.
- b) No brake isolation switch/s or drilled / lightened disc rotors allowed.
- c) The use of brake bias adjustment not permitted
- d) A.B.S Braking systems not allowed. Where A.B.S. only is fitted it must be converted to non A.B.S. system.

27. FUEL TANK / FUEL LINES

- a) Original tank to be removed.
- b) Fuel tank; may be fabricated – All metal tanks to be constructed of min 1.0mm steel or min. 3.0mm aluminum. - Maximum capacity 30 litres or 8 US gallons. Jerry can or boat fuel tank must comply with the above metal thickness. Maximum capacity 30 litres or 8 US gallons Plastic marine tanks accepted.
- c) Proprietary Fuel cells are highly recommended. When using a proprietary fuel cell, e.g. RCI The pick up supplied in side or bottom should be used. An earth strap to be fitted from the plastic fuel cell filler neck to the roll cage or body as an earth to prevent the buildup of static electricity.
- d) Rear of fuel tank to be not further back than the rear of the wheel arch, centrally mounted and securely mounted in OEM boot area. Fuel tank must not be mounted using brackets welded to the fuel tank. Fuel tank is to be isolated from the driver by a metal firewall.If using proprietary fuel cell it must be mounted against rear firewall and may protrude past rear wheel arch and must be mounted in a cradle.
- e) Fuel tank area must be accessible for scrutineering.
- f) Tank must have a non-spill breather pipe passing through a hole in the floor away from the exhaust system.
- g) Pick up and breather pipes to enter top of tank only. Except proprietary Fuel Cells
- h) Fuel line/pipe from fuel tank to engine, is to have a flexible section close to the tank, and to be securely fastened. Must be fitted with a driver operated tap, except EFI and to be suitably marked " FUEL " and the tap positions "ON/OFF".
- i) Neoprene fuel line using proper clamping practices may be used, or the original fuel system.
- j) The use of cooling systems for fuel is not allowed.
- k) Petroleum, no additives maximum specific gravity .780,maximum octane fuel 98 (RON) = **Research Octane Number**, octane unleaded fuel to be supplied by Shell, Caltex, Mobil or BP only. Must be supplied by commercial outlet through multi volume network via bowser pump and meet the fuel standard (Petrol) determination act.
Fuel may be tested by any means available.
Fuel Testing will be determined by the SSA Inc.

TABLE 1 ENGINE LIST FOR VEHICLE MODEL

If your model is not listed here with refer inquiry to your State SSA Technical Representative.

REFERENCE SOURCE - GLASS Dealer Guide

Maximum Capacity Engine

HOLDEN

EH - HD 179

HR - HG 186

HQ on 202

LC **Torana** 186

LJ **Torana** 202

LH - UC 202

Commodore VB 202 Red

Commodore VC - VK 202 Blue or 3.3

Commodore VL- RB30 or 3.3

Commodore VN - VR - 3.3 or series 1 and 2 V6

Commodore VS - VY - 3.3 or series 1,2 and ecotec

FORD

Falcon

XP 170

XR-XW 3.6

XY - XB 250

XC - XD 250 cross flow cast iron head

XD - XF 250 cross flow alloy head

EA - 250 or 3.9

AU - BA - 250, 3.9, 4lt or AU 4lt

Cortina

TC - TD 200

TD 250 cross flow cast iron head or log head

TE - TF 250 cross flow alloy head

Escort

MK 1 1300

MK 11 1600 cross flow (not OHC)

Capri

4 Cyl 1600 cross flow (not OHC)

DATSUN

1600 L16 engine

180B L18 engine

200B L20 engine

240K L24

260C L28

280C L28

1000 A10

1200 A12

3lt RB30 Nissan skyline

Mitsubishi

GE 1850 Astron

GJ on 2.6 Litre

Magna V6 6G74

CHRYSLER

Valiant

R - VF 225 Slant Engine

VF - VJ 245 Hemi

VJ onwards 265 Hemi

Charger – 265 hemi

Centura – 245 hemi

TABLE 2 BORE & STROKE

Type of Car	Bore	Stroke
4.1 Ford	93.47	99.31
3.9 Ford	91.86	99.31
4lt Ford	92.26	99.31
Centura	3.760	3.680
L.J. Torana 202	92.07	82.55
L.J. Torana 186	92.07	76.20
C'dore 202	92.07	82.55
Commodore RB30	86.00	85.00
Commodore V6	96.52	86.36
Magna V6 3.5	93.00	85.80
Sigma 2.6L	3.586	3.858
Charger 245	3.750	3.680
Charger 265	3.910	3.680
Skyline	86.00	85.00

TABLE 3 VALVE SIZES

Type of Car	Valve Size	
	Intake	Exhaust
4.1 Ford up to XE	44.00	38.20
Ford XF	45.70	38.20
Ford 3.9	47.00	39.00
Ford 4lt	47.00	39.00
Ford AU	47.00	41.00
Cortina 250ci	44.00	38.20
Centura 245	46.72	38.10
L.J. Torana 202	38.10	32.50
Torana 186	38.10	32.50
C'dore 202	41.25	36.00
C'dore RB30	42.10	35.10
C'dore V6	43.40	37.80
C'dore Ecotec VS	45.50	38.50
C'dore Ecotec VT onwards	46.63	38.74
Nissan RB30	42.10	35.10
Sigma 2.6L	43.00	35.00
Sigma GN 2.6L	46.00	38.00
Charger 245	46.83	38.10
Charger 265	50.00	40.87
Magna 6G74	35.00	30.50

TABLE 4 CARBURETTOR LIST

Make and Model of Car

EH-HZ All Engines include 3.3 "Red"	Single Throat Stromberg
Torana (except HB) inc 3.3 "Red"	Single Throat Stromberg
Commodore includes 3.3. "Red"	Single Throat Stromberg
Commodore 3.3 "Blue"	Varijet 11
Commodore 3.3 "Black"	Varijet 11
Cortina TC & TD 6 Cyl. not cross flow	Single Throat Stromberg
Cortina TD-TE-TF Cross Flow	Single Throat Stromberg
Falcon XK-XB all engines no cross flow	Single Throat Stromberg
Falcon XC-XD cross flow	Single Throat Stromberg
Falcon XE - AU 3.3 or 4.1	Weber 34ADM
Valiant VG-CM all "Hemi" engines	Dual throat Carter Email
Centura All models all "Hemi" engines	Dual throat Carter Email
Sigma All engines	Mikuni Down Draught 2BBL

TABLE 5 THROTTLE BODY

Butterfly ID to be measured parallel to throttle shaft.

MAKE	THROTTLE BODY OUTER SECTION I.D.	BUTTERFLY SECTION I.D.
Falcon		
XF	70mm	64mm
EA - AU	64mm	64mm
Commodore		
VK	68mm	65mm
VL	64mm	54mm
VN - VR	72mm	60mm
VS - VY	72mm	64mm
MAGNA 6G74		65mm
Nissan Skyline		
RB 30	64mm	54mm

TABLE 6 COMPUTER AND INJECTOR LIST

All commodore engines after VP are to use VP computer

All Falcon engines after EB are to use EB computer and V6 Magna TF

VK COMMODORE	550803	BOSCH	0280001305
HOLDEN	IGM206		
VL COMMODORE	550805	BOSCH	9260060002
HOLDEN	IGM112		
VN-VP C'dore	550801		
HOLDEN	1227808		
XF FALCON	550703	FORD	84DA12A650MA
	550705	FORD	86DA12A650BA
EA	550706	FORD	87DA12A650C CFI only
EA – EB	550706	FORD	87DA12A650A/87DA12A650B
			87DA12A650D
	550707	FORD	90DA12A650A/90DA12A650B
Skyline	550805	BOSCH	9260060002

Standard fitment fuel injectors

Ford	XF Leaded fuel	0280150203	200	16.2
	XF Unleaded	0280150726	204	14.5
	EA/EB CFI	0280150065	812	1.3
	EA-EL Multipoint	0280150736	199	
	Or	0280150790	199	15.9
	AU	0280155844	200	14.5
Holden	VN Series 1	0280150901	195	14.5
	VN/P/R Series 2	0280150960	200	14.5
	VS Ecotec	0280150973	203	12.0
	VT/VX/VY	0280155777	200	12.0

TABLE 7 STANDARD DIMENSIONS

These are maximum measurements including 15mm absolute tolerance for track

Model	W/base mm	Front-Track-Rear mm	mm
HOLDEN			
LJ	2540	1336	1310
LH/LX	2591	1412	1387
VB-VK	2668	1465	1435
VL	2668	1465	1435
VN	1732	1470	1495
VP	2731	1466	1493
VR-VS	2731	1506	1506
VT - VZ	2788	1585	1605
VE	2915	1617	1633
FORD			
TD	2581	1437	1437
TE	2578	1441	1441
TF	2580	1535	1535
XD	2818	1575	1541
XE	2790	1567	1552
XF	2829	1562	1540
EA	2794	1561	1548
EB- ED	2794	1569	1569
EF - EL	2791	1581	1562
AU	2793	1581	1562
BA	2829	1568	1586
FG	2838	1598	1613 (valid from 1/7/2013)

CHRYSLER-MITSUBISHI

KB/KC	2667	1422	1412
CL	2819	1496	1512
Magna TF	2722	1545	1535

SIGMA

GH	2515	1385	1363
GN	2530	1395	1365

NISSAN

RB30	2610	1450	1425
------	------	------	------

TABLE 8 TYRE RATINGS

Tyres - Radial only
 215mm maximum width on side wall markings.
 Minimum 60 series profile.
 Speed rating H maximum.
 E.g. 215/60/R or 215/75/15H

TYRE RATINGS

SPEED RATING

A1 – A8	5-40	kmh
B	50	kmh
C	60	kmh
D	65	kmh
E	70	kmh
F	80	kmh
G	90	kmh
J	100	kmh
K	110	kmh
L	120	kmh
M	130	kmh
N	140	kmh
P	150	kmh
Q	160	kmh
R	170	kmh
S	190	kmh
T	200	kmh
U	200	kmh
H	210	kmh

DRAFT

Notes