

TABLE OF CONTENTS

SECTION 1 – Policy, Procedures, and Definitions	
1. Interpretation.....	3
2. General.....	3
3. Declaration of Compliance.....	4
4. Registration.....	4
5. Measuring of Cars	4
6. Penalties.....	6
7. Authority to Exclude	6
8. Definitions and Clarifications.....	6
SECTION 2 – Personal Safety Equipment	
9. Driver Safety and Protective Clothing.....	8
10. Seat Belts.....	9
11. Installation of Driver Restraint Systems.....	10
12. Adjustment of Driver Restraints.....	12
13. Window Nets.....	12
14. Padding.....	13
15. Fire Extinguisher.....	14
16. Seat.....	14
SECTION 3. – Class Specifications – Super Sedan	
Compilation of Specification Manuals	16
17. General Construction.....	17
18. Super Sedan Weight Limits.....	17
19. Width of Race Car.....	17
20. Chassis.....	17
21. Roll Cage	20
22. Additional Roll Cage Bar Work Required.....	24
23. Anti-spear Plate.....	25
24. Head Plate.....	26
25. Window Mesh.....	28
26. Ballast	28
27. Bumper Bars	28
28. Over Ride Bars	30
29. Towing Points	31
30. Rub Rails	31
31. Fuel Tank Protection	32
32. Wheelbase	33
33. Suspension	33
34. Panhard Bars.....	34
35. Shock Absorbers	34
36. Steering	34

37. Brakes	35
38. Wheels	35
39. Tyres	36
40. Engines	37
Engine Block	37
Cylinder Head	38
Crankshafts	38
Induction	38
Ignition	38
Fuel	38
Exhaust System	39
Cooling System	40
Engine Position	41
41. Transmission and Drivetrain	44
42. Battery and Electrical System	45
43. Fuel Tank and Fuel System	45
44. General Body Fitment	46
45. Bonnets and Boot Lids	49
46. Rear Spoilers	50
47. V8 Supercar Wings	51
48. Flared Wheel Arches	52
49. Presentation and Signwriting	52
50. Interiors and Firewalls	52
51. OEM Bodied Cars	53
52. 5 Star Bodied Cars	53
53. Body Specifications for 5 Star Short Track Bodies	54
54. Short Track Bodies 2004 onwards	56

© All rights reserved. Reproduction or translation of this Manual, in whole or part is not permitted without written authorisation from Speedway Sedans Australia Inc.

SECTION 1 – Policy, Procedures and Definitions

1. INTERPRETATION:

The Speedway Sedans Australia Inc. (SSA Inc.) shall direct the enforcement of these specifications in all aspects.

The SSA National Technical Committee shall be the sole authority for the interpretation of the specifications as contained in this book and any circularised amendments.

AMENDMENTS to this Manual may be made during the life of this Manual for the reasons as set down in SSA Inc. Policy governing such amendments. The amendments will be approved by the SSA Inc. Board and circularized to all Clubs and competitors by way of a Media Release and/or in Tek Torque. A stick-in advising this amendment will be provided in the front of all Manuals purchased after the amendment becomes law. Amendments circularized in such manner, shall be deemed to be as valid as the contents of this manual and must be adhered to by all Competitors and Scrutineers.

Specific decisions made by National/State/Zone Officers shall be subject to ratification by the National Technical Committee, after due notice of the decision and reasons have been given.

All enquiries must be directed through your local Club Scrutineer to your state technical delegate.

SSA Inc. cars must only race with SSA Inc. Registered cars, with SSA Inc/NASR Licenced drivers with SSA Inc. approved Insurance

2. GENERAL

Specifications listed in this book are a guide to building race cars. If "IT" is not in the book, it will be considered illegal until written approval for use is issued by the National Technical Committee after ratification by SSA Inc. Board.

Before constructing cars of unusual or unconventional design, full details are to be submitted in writing to the SSA Inc. Technical Committee via Club and State Secretary. If requested, this submission shall be handled "CONFIDENTIAL" and

approval, or required modification before approval, shall be given in writing to the applicant. An administration fee applies.

3. DECLARATION OF COMPLIANCE:

The PERSON RESPONSIBLE for the LEGALITY of the car will complete a SSA Inc DECLARATION OF COMPLIANCE ANNUALLY.

Declaration will cover ELIGIBILITY for class and ALL points of SAFETY including material specification and sizes. Details of the declaration are to be placed in the log book.

Registration is not complete until Pages **3 to 6** of the LOG BOOK are completed and signed by both the Owner/Driver AND the Scrutineer/Machine Examiner or Registrar.

Structural or other specification changes made during the year MUST be notified to the respective Officials and adjustments will be made to the Log Book if required. The Driver must have an SSA Inc/NASR licence and an SSA Inc. Infringement Card.

4. REGISTRATION:

An SSA Inc new registration can only be issued for a race car, provided that the car conforms to the SSA Inc Specification Book for the Class in which the car is to be registered.

The car must pass an annual registration examination and a registration decal will be issued and must be attached to a prominent location on the car.

A chassis and roll cage being re-registered must have the log book from the immediate previous season otherwise it will be required to comply with new car specifications. The DRIVER is responsible for having the log book further endorsed before participation in each official practice session or race meeting.

A log book without endorsement by the Machine Examiner is equivalent to a no-race ticket.

5. MEASURING OF CARS:

All cars are subject to engine and general measurement at any time by a Scrutineer, State or National Technical Committee OR at the direction of the National Technical Director, or the National Technical Committee, or the Steward, or the Racing Disputes Committee. **The SSA Inc. reserves the right to inspect any race car at any time, including downloading of information via computer and confiscate and store as per Tek Torque.**

Cars can be selected at random and ordered to the impounded area for dismantling.

The entrants of the cars must deliver them immediately upon request and supply the necessary manpower and hand tools to accomplish dismantling.

Only persons actually involved in dismantling the car will be allowed in the immediate area of a vehicle being checked. Persons associated with other cars being checked are to remain with their own car. Any persons not having cars in the impound area, and gaining entry without authorisation, will be ejected.

If there are no facilities available to check any parts of a vehicle, sealing of parts under question can be carried out and vehicle taken to a mutually agreed venue for examination at another time, but within fourteen (14) days.

Impounded cars will be stored at the owner's risk. Although every reasonable precaution will be taken, no responsibility for fire, theft or damage will be assumed by the SSA Inc and/or affiliated clubs.

Wheel Base Measurement;- With each front wheel pointing straight ahead, measure distance from front axle centre to rear axle centre on each side of vehicle. Add dimensions for left and right, divide by 2. Allowable tolerance +/- 1%. See Fig. 1.

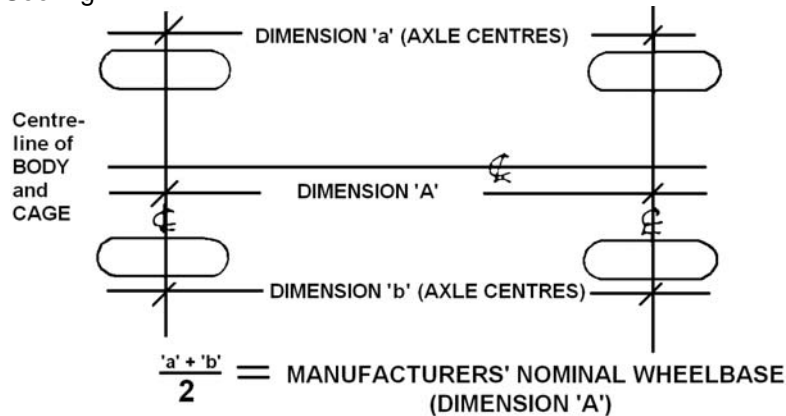

Fig. 1

Chassis Centre line:- Defined as the mid-point between the outside of both outriggers in the cabin chassis area. This is calculated by dividing the measurement between the outside edges of the two outriggers by two.

Absolute Body Width Measurement:- Measured at the waistline of the body fitted to the chassis.

Engine Capacity:- Determined by measuring the bore and stroke of the engine, calculating the swept volume of one cylinder and multiplying that figure by the number of cylinders in that engine.

$$CC = 0.7857 \times (\text{bore}/2) \times (\text{bore}/2) \times \text{stroke} \times \text{no of cyl}$$

Engine Setback:- Measured at the rearmost point across mating face of engine to transmission to centreline of rear axle.

6. PENALTIES:

This Manual must be read in conjunction with the Australian Speedway Racing Rules and Regulations and/or notices issued by the SSA Inc. from time to time.

Ignorance of these Regulations and Specifications and notices shall be deemed as no defense in regard to breaches and/or appeals of same.

7. AUTHORITY TO EXCLUDE:

If an SSA Inc Official determines prior to the race that the Race Car does not meet the applicable specifications, the car will not be allowed to compete unless, in the discretion of the official, the deficiency:-

- a. will not adversely affect the orderly conduct of the race.
- b. will not provide the competitor with a significant competitive advantage over other competitors.
- c. is so insubstantial as not to warrant a determination that the car is ineligible to race.

If the Official permits the car to compete under these circumstances, the Official will advise the competitor in writing of the deficiency, and if the deficiency has not been corrected, within the allotted timeframe, the car will be prohibited from competing in any future event.

8. DEFINITIONS and CLARIFICATIONS

5th Arm- Traction Device.

Blade - Flat inclined surface of a wing.

Cabin Chassis Area- Is the base of the chassis that the roll cage legs mount to, and is called the minimum floor area which is 900mm x 1445mm.

Carburetor- Is to have all working parts in use, e.g. needle and seat, fuel bowl, float, jets etc and fuel is to be naturally delivered to the main jet by atmospheric pressure. The air pressure in the carburetor venturi being lower than atmospheric pressure, allows fuel then to flow from the bowl to the carburetor venturi as the pressure in the carburetor throat decreases. Fuel is then drawn down the venturi and carburetor throat by vacuum provided by the rotation of the engine.

Chassis- The rectangular steel frame, supported on springs and attached to the axles, that holds the body and motor of an automotive vehicle

Engine- Means all of the components making the engine function, meaning complete engine, including rocker covers, excluding exhaust manifolds.

For the purpose of this manual:

Inch- 1in = 25.4mm

Kilogram- 1kg = 2.2lbs

Material:

CHS - Circular Hollow Section.

FMS - Flat Mild Steel

RHS - Rectangular Hollow Section.

w.t. - Wall thickness.

AS1163 Gr300 - Australian Standard 1163 for structural steel tubing Grade 300

O.D. - Outer Diameter

OEM - Original Equipment Manufacture; used to indicate parts used on the complete vehicle as it left the production line from the original manufacturer and means for make and model unless otherwise stated.

O.H.&S – Occupational Health and Safety

Replica Body- means the Body is dimensionally correct to the original manufacturer's specifications.

Window Net - A lattice of 19mm woven webbing fixed between the top roll cage bar and the top NASCAR bar.

SECTION 2 – Personal Safety Equipment

9. DRIVER SAFETY

All protective clothing and safety equipment must be used and/or worn in the approved and accepted manner whilst competing, or testing and/or practice.

All race wear / equipment to be inspected at each practice/race meeting.

Illegal parts or safety equipment will be confiscated and stored by State where event is being held.

PROTECTIVE CLOTHING:

The following are minimum safety standards:-

RACE SUIT: Minimum standard of either SFI 3.2A/5 or FIA 8856-2000. A snug fit at ankles, collar and cuffs, and must be fully fastened at all times whilst in the car.

UNDERWEAR: Comply with SFI 3.3, FIA 8856-2000 or FIA ISO6940 (FIA ISO6940 allowed until June 30, 2010) and must be worn. Drivers must only wear cotton socks and under-garments e.g. No synthetic boxer shorts, and no under wires on bras. No synthetic attire and no jewellery to be worn by a competitor whilst completing.

BALACLAVAS: Comply with SFI 3.3, FIA 8856-2000 or FIA ISO6940 (FIA ISO6940 allowed until June 30, 2010) and must be worn.

BOOTS: Comply with SFI 3.3, FIA 8856-2000 or FIA ISO6940 (FIA ISO6940 allowed until June 30, 2010)

GLOVES: Comply with SFI 3.3, FIA 8856-2000 or FIA ISO6940 (FIA ISO6940 allowed until June 30, 2010) It is recommended they are the Gauntlet style and must NOT be modified in any way.

HELMET: Full faced and comply with the Snell SA-2000 (Snell SA-2000 expires June 30th 2010) Snell SA-2005 or Snell SA-2010 Standard and must be no older than 5 years from the manufacturer date. The higher Snell standard helmet can be used and is recommended. However, if helmet is misused, neglected, or damaged, it may be rejected and impounded by Machine Examiner or Technical Committee at any time, and if considered to be unsafe, scrutineers log book entry to be completed along with drivers log book and helmet cannot be used again for any speedway event. Chin cup on helmet not permitted. Spectacles, visor or sunglasses, when worn, must have lenses of non-splinterable material.

HEAD AND NECK RESTRAINT: Meet FIA and/or SFI 38.1 Standard and must be worn. (A horse collar is optional when wearing a Head and Neck Restraint).

10. SEAT BELTS

An approved type racing harness must be fitted, using a minimum of four major belts and four mounting points, plus one or two anti-submarine/crotch straps. Shoulder and Hip Belt width 50mm minimum, 75mm highly recommended.

Only belts with over centre lever lock buckle to be used.

SEAT BELT LIFE IS A MAXIMUM OF FIVE YEARS FROM DATE OF MANUFACTURE

Shoulder belts are to have separate anchor points/adjusters. Fig 2 (i)

Shoulder belt mounting points shall be positioned to the rear and below the point at which the shoulder belts come through the seat and be not more than 300mm from that point, attached to 38mm x 3mm tube. See Fig 2 (ii)

Lower seat belt mounting brackets (anchor points) must be on roll cage and chassis or substantial barwork using a minimum construction of 25x25x3mm RHS or 25mm OD CHS. Seat belt attachment tag to be 3mm minimum mild steel.

Anchor bolts to be 10mm steel min.

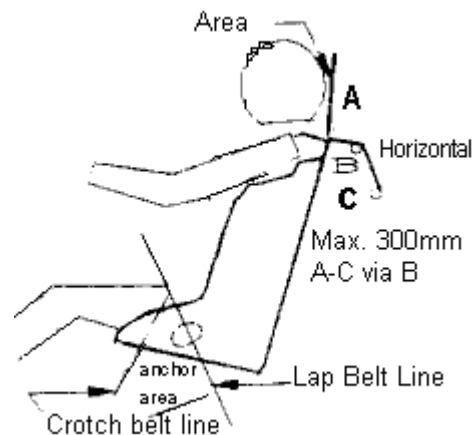

Fig. 2(i)

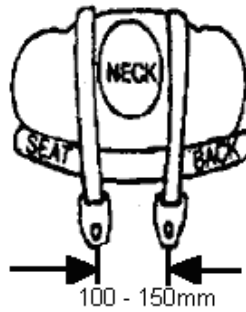

Fig. 2(ii)

11. INSTALLATION OF DRIVER RESTRAINT SYSTEMS

In order for the driver restraint system to be fully effective, considerable thought must be given to the location of mounting points, and to proper installation.

With the seat, roll cage and belt anchors all part of the same structure, deformation of the remainder of the car does not put driver at serious risk.

The mounting points must be solid and should remain so even if the vehicle is deformed due to an accident. The mounting points should also not put undue strain or twist on the belt system hardware.

The lap belt should be positioned so it rides across the solid pelvic area and not the soft stomach area or down on the thighs. The shock absorbing ability of the pelvic area and its ability to protect internal organs make it the preferred location for the lap belt. See Fig 3 (i) & (iii).

The shoulder harness should be mounted to prevent driver's shoulders from moving forward (upward if semi-reclining), out of the seat, in the event of a rollover.

Anti-submarine straps serve two purposes;

1. To secure the lap strap down across the driver's hips, so in the event of an accident, it is not pulled up across the stomach by the shoulder straps.
2. To prevent the driver from sliding forward and out of the harness. When the driver is seated in an upright position, as in most sedans, a five point system (a single anti-submarine or crotch strap) is considered adequate (Fig 3 ii). For extra assurance a double strap anti-submarine belt can be used. (Fig 3 iv)

When the driver is seated in a semi-reclining position a six point system (two anti-submarine or crotch straps) is preferable. Most drivers find the two anti-submarine strap system more comfortable. In many instances, the anti-submarine straps are mounted much too far forward of the seat.

This practice could cause unnecessary injury as the body can slide partially out of the seat before being restrained when the strap contacts the groin. It is much more practical to cut a slot in the seat bottom so the anti-submarine strap can be anchored in line with the chest. (Fig 3 (i))

Because of the differences (often vast) in competition vehicles, a 'standard' method of mounting is impractical. Good judgement and common sense in inspecting restraint system mounts is needed.

Safety equipment is often neglected in favour of performance equipment, but its proper operation when the need arises is essential to survival.

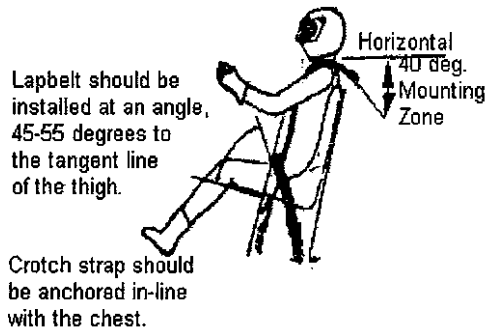
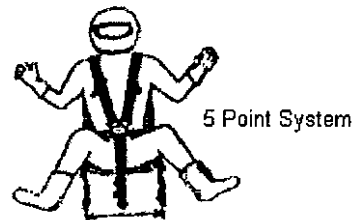

Fig. 3(i)



Seat belts should be anchored apart the same distance as the driver is wide. Mounting brackets should be angled the same direction as belts pull and not tilted in or out.

Fig. 3(ii)

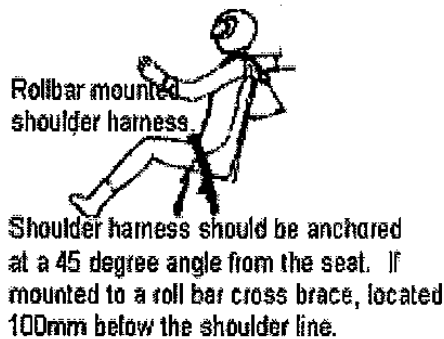
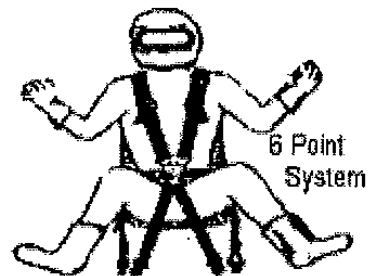

Fig. 3(iii)



Crotch strap mounts as far apart as comfortable.

Fig. 3(iv)

12. ADJUSTMENT OF DRIVER RESTRAINTS

With the driver fully kitted out in 'underwear and driving suit', check that, with the driver seated, belt slots in the seat line up with natural line of the belt from anchor to buckle when just the lap belt is tensioned.

Ensure that the lap adjusters do not foul the seat and that they are readily accessible. Some belts adjust by pressure downward others by pull up.

Check that the driver can manipulate belt adjusters with gloves ON.

Check also that anchor hardware is aligned and that it is not possible to have a hitch in the anchor area without detection (sudden release of the belts to 50mm slack can put the driver off-line).

Now check if the belt is holding the seat or the driver, it should be the latter.

Adjust the anti-submarine strap/s to ensure that the buckle is held flat and close to the body over the pelvis. When satisfied that the lap belt is OK, put on the helmet and check just how far the helmet (with visor) can reach, head plate clearance, helmet/window net etc.

Slacken the seat belt, engage the shoulder belts into the buckle and tension the seat belts again, checking position of the buckle and adjusters.

Tension each shoulder belt, checking that the adjustment range is suitable to the driver, that the belts and hardware don't foul the seat and that the natural line of the belts holds the driver as with the lap belts.

Note also any change in the buckle location and lay. If there is too much variation with the buckle it would appear that lap anchors are not in optimum position.

Before drivers releases the buckle he should slacken shoulder belts with the adjusters, keeping the area of the adjuster supple, accessible for cleaning and making entry to the car a simple routine.

13. WINDOW NET

The use of a window net is mandatory.

Net is to be a minimum 19mm woven webbing with 75mm max hole size. See Fig. 4

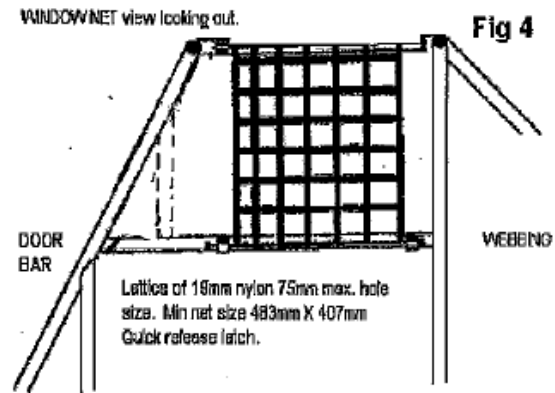

It is recommended that the window net be hinged from the bottom.
Rod thickness to be minimum 6mm (1/4")

Window net must be mounted directly to the roll cage bar (top) and NASCAR bar (bottom) from the quarter window bar (if fitted) back.

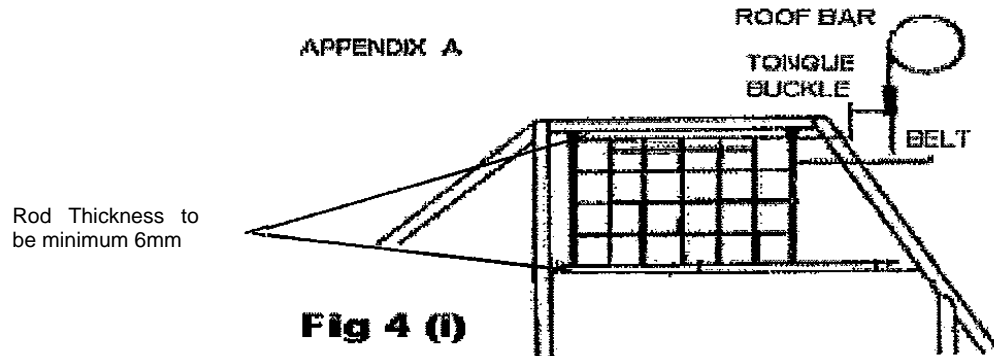

This design (Fig. 4(i)) uses two push button seat belt buckles and belts. Tongues are welded to side roof bar. 25mm x 3mm FMS welded to rear of buckles. Tubing or rod at the base of window net is to be fixed with bonnet lock pins or similar.

14. PADDING

The driver must be protected, in the race car, from all sharp edges and projections or barwork, which could cause injury in an accident.

15. FIRE EXTINGUISHER

On board fire extinguisher permitted. It must be securely mounted and be of the correct type for the fuel being used.

16. SEAT

A "Purpose Built" one piece, solid (i.e. no lightening holes), steel, aluminium, or fibreglass bucket type seat incorporating a substantial head rest must be used. Plastic seats are not permitted. Minimum thickness of aluminium and steel seats is 3mm. The minimum thickness of a fibreglass seat is 5mm.

Approved proprietary line competition seats and mounts are permitted.
Eg. Kirkey, Butler, United Speedway Accessories, Bratpac and Racetech.

Magnesium alloy seats not permitted.

Lateral (sideways) support must be given to hips and above waist.

Concave seat to support back to minimum of TOP of shoulder height and width.

The seat is to be mounted completely on the right hand side of the vehicle centreline.

The seat base is to be mounted to roll cage chassis at a minimum of two points using 8mm bolts and minimum of 40mm diameter body washers. (Four points are recommended.)

Seat back is to be braced and attached to the roll cage approx 75mm below shoulder height using a minimum of two 8mm bolts and 40mm body washers. There is to be a minimum 50mm clearance between the helmet and the head plate/hoop bar.

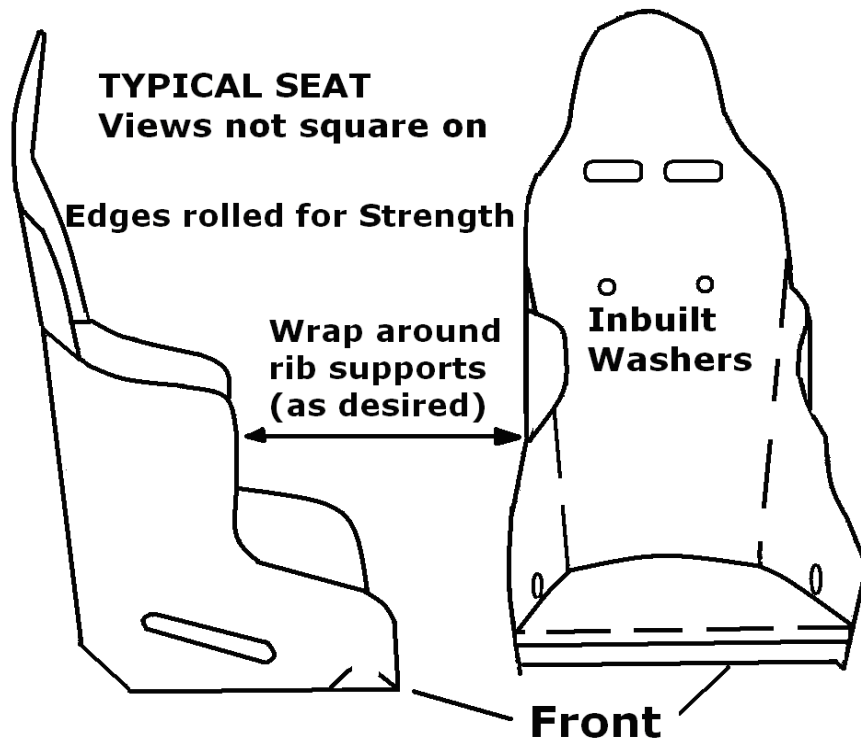

Fig 5

SECTION 3 - CLASS SPECIFICATIONS -

SUPER SEDANS

A Super Sedan is a full chassis race car built to be representative of a Sedan, or full hard turret Coupe bodied passenger car.

Four wheel/all wheel drive and/or four wheel steer models are acceptable but must be used in a FRONT steer and TWO wheel drive configuration only.

COMPILATION OF SPECIFICATION MANUALS.

- a) Drivers' meeting.
- b) Drivers' meeting proposals collated by State Technical Officer.
- c) Drivers' meeting proposals reviewed by SSA Inc. State Body.
- d) Final State proposals forwarded to SSA Inc. National Office setting out-
 - Reasons for proposals.
 - Proposed wording for any new specifications.
 - Copies of driver/club/state correspondence or minutes regarding the new specifications.
 - The state will provide an analysis on the effect the new proposals may have on the class.
- e) National Technical Advisor, in conjunction with the SSA Inc. National Office collates all proposals and forwards on to members of the National Technical Committee.
- f) Each State conducts a State drivers' meeting to review all of the proposals.
- g) Recommendations from State drivers' meetings are forwarded to SSA Inc. National Office through the respective State Office.
- h) National Technical Committee to use these recommendations to develop the specification book final draft.
- i) Board to ratify this final draft.
- j) A nominated National Technical Committee member will be responsible for the compilation of this final draft into printed version.
- k) The National Technical Advisor will check the final print version of the specification manual for accuracy.
- l) The final print version of the specification manual will be presented to the SSA Inc. Board.
- m) The final version of the specification manual may be placed on the relevant web site.

17. GENERAL CONSTRUCTION:

General workmanship on race cars is to be of professional standard and all materials used must be of good quality.

New race cars must be of chassis construction.

Front wheel drive models may be converted to front engine with rear drive, using nominated wheelbase. Chassis with bodies representing rear or mid engine vehicles must retain the OEM engine position for that body.

All material sizes quoted are a minimum specification unless a maximum is stated.

No cabin adjustments allowed except for brake bias and brake shut off valve.

No electric, electronic or hydraulic adjustments allowed.

18. SUPER SEDAN WEIGHT LIMITS

Minimum weight including driver,

V8's and V12's	1100 kg =	2420 lb
6 Cylinder and Rotary	1000 kg =	2200 lb
4 Cylinder	900 kg =	1980 lb

Vehicles will be weighed at the completion of an event.

19. WIDTH OF RACE CAR

Body width is not to be less than original manufacture. Maximum width of the body including rub rails is 1960mm. Overall width of vehicle is 2110mm ABSOLUTE. Fig. 6(i)

20. CHASSIS

Chassis Cabin Width: Material: mild steel 75x50x3mm RHS minimum (Sonic test at not less than 2.7mm w.t. ABSOLUTE). The chassis shall be full width of the cabin area and be symmetrical along the cabin area centreline. Measurement from right hand side centre waistline bar into chassis/outrigger to be a maximum of 255mm. Fig. 6(i)

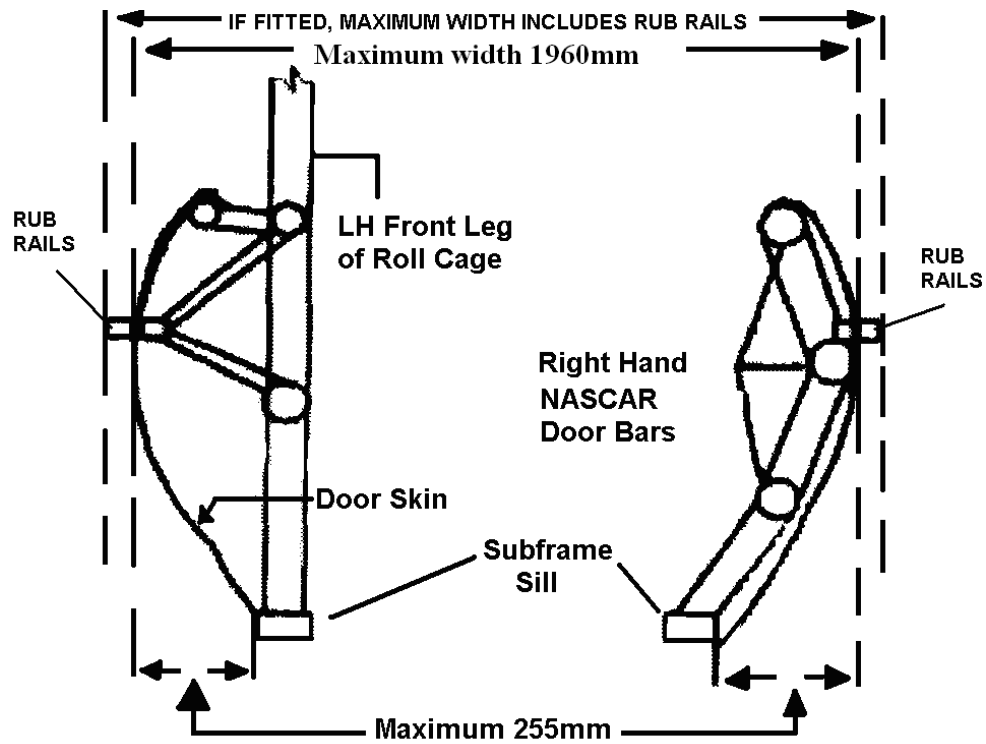

Fig. 6(i)

Front Chassis. Material: mild steel 75x50x3mm RHS minimum. (Sonic test at not less than 2.7mm w.t. ABSOLUTE). Front: Chassis rails must extend forward of the front axle centerline minimum 380mm and is symmetrical to the cabin chassis area.

Rear Chassis. Material: mild steel 75x50x3mm RHS minimum. (Sonic test at not less than 2.7mm w.t. ABSOLUTE) Rear chassis rails must extend from the centerline of the rear axle REARWARD a minimum of 610mm and have the fuel tank mounted in this area. Maximum rear chassis rail offset 75mm of symmetrical. Angle of rear chassis rails must be a minimum of 45° and a maximum of 70°. Fig 6(ii), 6(iiii).

All material in fabricated chassis, chassis outriggers and/or sub-frames are to be of mild steel, minimum of AS 1163 Grade 300.

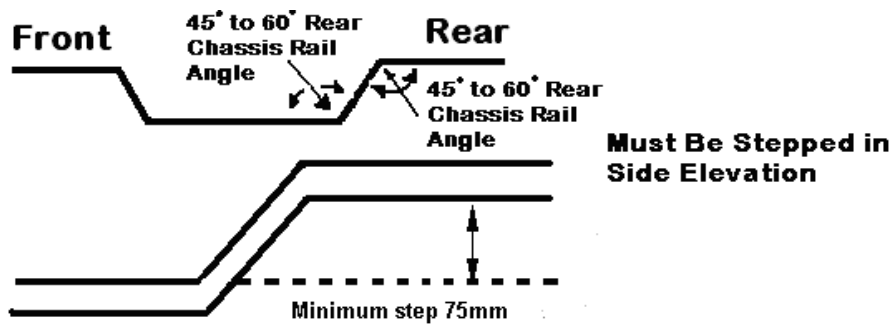
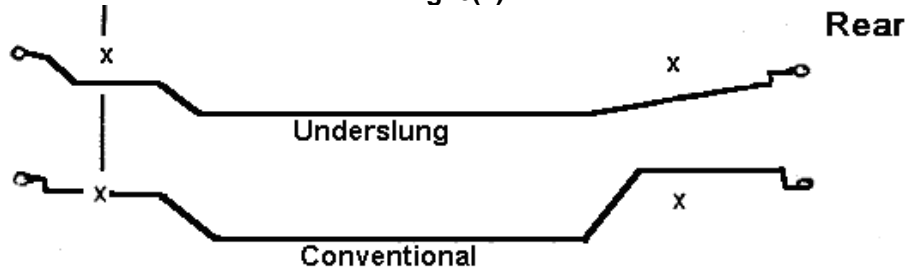

Fig. 6(ii)



Chassis designs vary greatly but ALL designs MUST provide adequate crush zone for DRIVERS SAFETY

Fig. 6(iii)

Both chassis rails, fore and aft of cabin area, must be stepped a minimum of 75mm when viewed in side elevation, to create a crush zone.

Front crush member to be minimum 305mm length of 38mm OD x3mm CHS.

OPTION 1 Chassis rails must not extend beyond the bodyline.

OPTION 2 Underslung chassis; front and rear crush zones 305mm minimum. If bend is used to form the crush zone, chassis is to stop short enough to allow fitment of bumper mountings. See Fig. 6 (iii)

Minimum of two sub frame cross braces at roll cage legs, either 38mm OD x 3mm CHS or 35x35x3mm RHS. Fig. 6(iii)

Lightening of chassis material not permitted.

Wheels must be mounted outside of front/rear chassis rails.

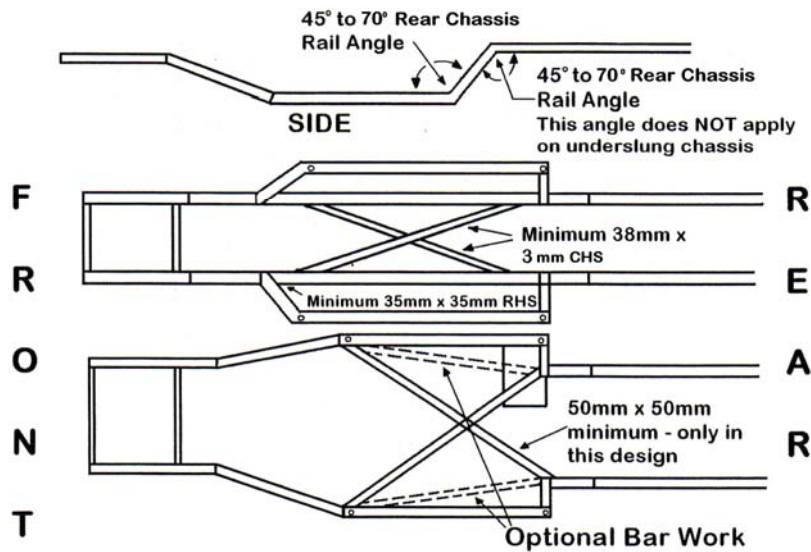

Fig. 6(iv)

21. ROLL CAGE

The roll cage is to prevent the collapse of the cabin area under impact.

The roll bars are to constitute a cage type framework, braced fore and aft. The cage must extend from behind driver's seat forward to the windscreen area and incorporate protection for the driver's feet.

Roll cage, to enclose the driver, is to be symmetrical about the front to rear centreline of the chassis and original (size) roof panel and be full height of the cabin chassis area.

Use of other than mild steel materials not permitted.

All roll bar material must be of good quality mild steel, minimum AS 1163 Grade 300. MINIMUM 38mm OD x 3mm CHS. (Sonic test at not less than 2.70mm ABSOLUTE.

All bends to be made using a bender with the correct size former.

Galvanised tubing or welding over threaded tubing is not permitted in any structural bar work.

Water pipe fittings or malleable fittings are not permitted.

Roll cages built using other than fusion-welding techniques will not be accepted.

Gussets on welded joints may be required. (Daylight inspection).

All bar work is to be inside the body.

The main hoop of the roll cage is to be not less than 355mm forward of the rear axle centreline. Fig. 7(i)

Roof area of the cage is not to be less than 760mm long and 1065mm wide. Fig. 7(i)

Minimum floor area to be 900mm x 1445mm as per Fig. 7 (ii)

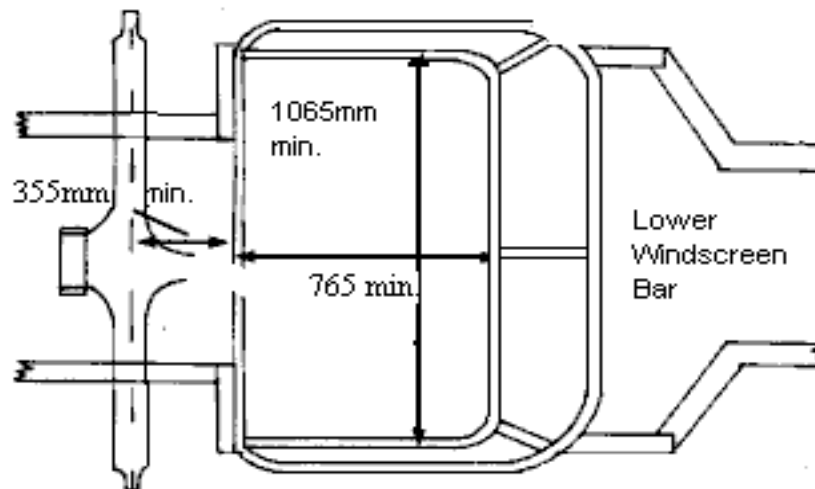

Fig. 7(i)

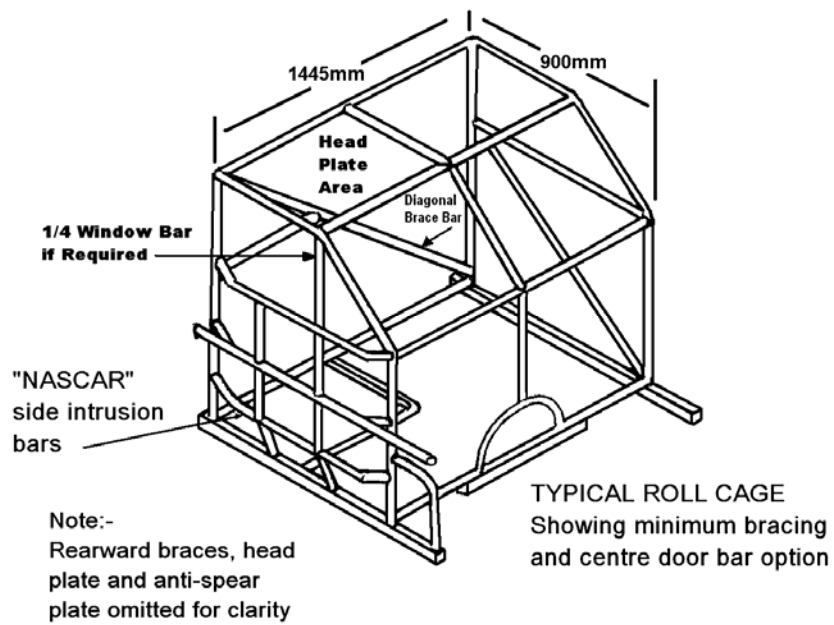

Fig. 7(ii)

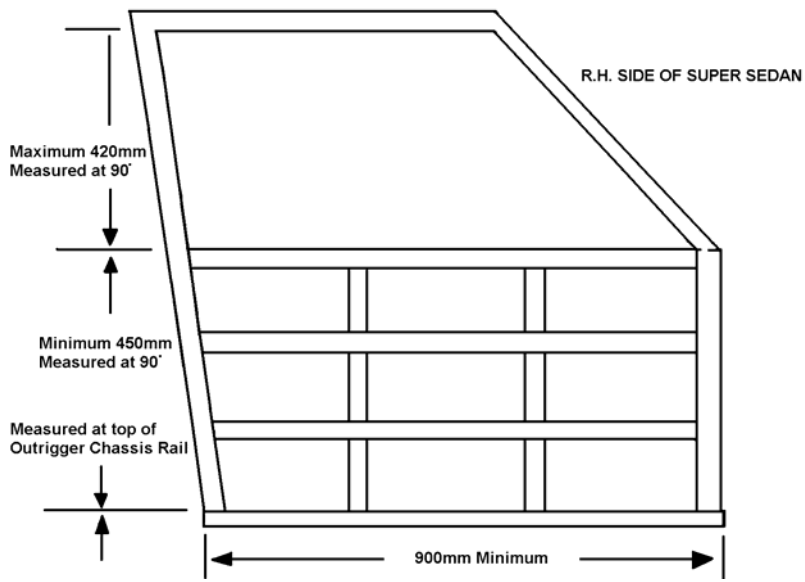

Fig. 7(iii)

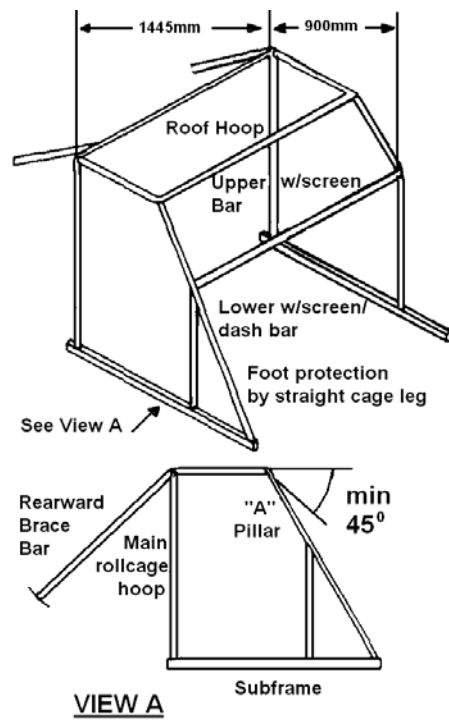

Fig. 7(iv)

Angle of roll cage "A" Pillar bar to be of not less than 45 degrees down from roof bar. Fig. 7(iv)

Roll cage legs shall be welded to the top of the chassis rails running fore and aft. As per Fig 7(iv)

The rear main hoop and main roll cage bars will each be made of one continuous length of tubing, with smooth continuous bends and no evidence of crimping, wall failure or significant weakening. Fig 7 (v)
Rear main hoop must be mounted left side to right side of chassis outrigger.

A one piece diagonal brace, minimum 38mm OD x 3mm CHS will be fitted in the main roll cage hoop behind the driver's head, within 250mm of the corner and down onto the left side chassis rail or roll cage leg. (Top right to Bottom left) Fig 7(ii) & 7(v)

A second brace may be fitted in cruciform. The diagonal brace, top right to bottom left, must be one piece. Fig 7(v)

If a cruciform type bracing is used a minimum of 32mm OD x 3mm CHS may be used.

The bar providing the anchor points for the shoulder belts is to be positioned so that belts are anchored a maximum of 300mm from the rear of the shoulder belt opening of the seat. Fig 7(v)

Bolts are not to be used through structural tubing in the roll cage cabin area unless a welded sleeve is provided. No pop rivets, tech screws or self tapping screws to be used in roll cage tubing.

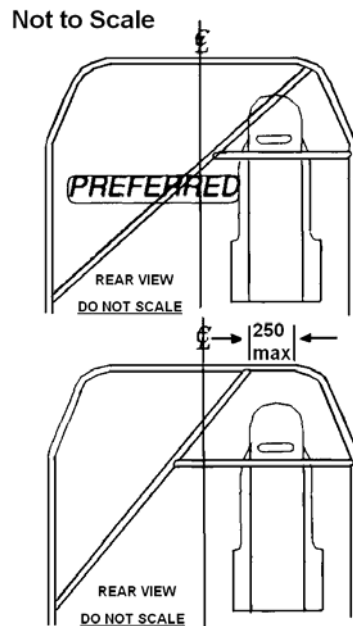

Fig. 7(v)

22. ADDITIONAL ROLL CAGE BARWORK REQUIRED

38mm OD x 3mm CHS

Top windscreen bar

Lower windscreen/dash bar

Seat back support/shoulder belt mounting bar

On drivers (right) side: three horizontal side bars, curved out toward the door skin, are to be placed between front and rear cage legs, evenly spaced as per diagram. Fig. 7 (iii)

An inspection hole, min. 300mm x 300mm to be available in RHS inner door cover to inspect Nascar bars. Hole may have a quick release cover.

A minimum of two vertical spacer bars, evenly spaced between front and rear roll cage legs, are to be fitted between the cage sub-frame and top horizontal bar. Fig 7 (iii)

Centre NASCAR bar must return to roll cage or chassis at front.

Passenger's (left) side; two bars between front and rear roll cage legs.

One must be horizontal at window sill height same height as right side NASCAR bar. Fig. 7(ii)

Minimum of two sub frame cross braces at roll cage legs, either 38mm OD x 3mm CHS or 35x35x3mm RHS. Fig. 6(iv)

A quarter window bar, if required because of excessive rake or a long roll cage, be fitted to both sides and installed from the top NASCAR bar to top half of pillar bar using minimum 25x3mm CHS (Recommended 38mm x 3mm CHS). Alternately, a 38 x 3mm O.D. bar may be fitted from top of 'A' pillar bar to top of NASCAR bar at 45° of the top bar on both sides.

Centre roof bar, 32mm OD x 3mm Black Pipe

Centre windscreen bar, 25mm OD x 3mm Black Pipe

Rearward brace bars from the top rear of main hoop down onto rear chassis (approx 30 - 45 degrees). They may form a crucifix and must be attached to the rearward side of the hoop within 100mm of the centre of the top radius. Material to be a minimum of 34mm CHS. Fig.7(iv)

23.ANTI-SPEAR PLATE

An "anti spear" plate, of 3mm steel or 5mm alloy, must be fitted. as per Fig. 7(vi). It must be solid and cannot be lightened by drilling. It is recommended that it be 1/3 the length between roll cage legs, fitted on driver's side, from floor-line to window sill bar, forward of the first vertical door bar to the front leg of the roll cage. Fig 7 (vi) If not welded, one piece external door plate to be bolted on, using a minimum of 6 – 50mm x 50mm x 3mm MS tags and either 8mm or 5/16th high tensile bolts with no protrusions.

If individual pieces are used then a minimum of 4 – 25mm x 25mm x 3mm MS tags per piece, and bolted to either 8mm or 5/16th high tensile bolts to each piece, with no protrusions.

If foot protection is required it is to be constructed out of roll cage material. An extension of the anti-spear plate is also recommended. See Fig 7(vi).

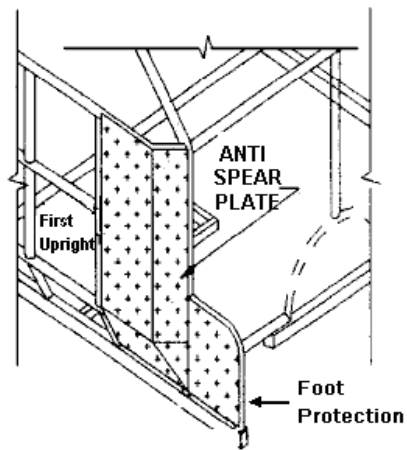

Fig. 7(vi)

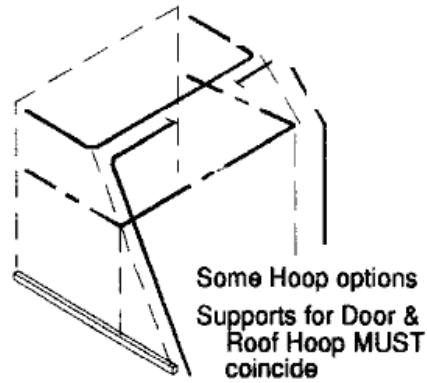

Fig. 7(vii)

24. HEAD PLATE

A minimum 50mm helmet clearance is required between roll cage pipes and head plate.

To simplify removal of an injured driver, the use of a removable full size head plate is highly recommended: Fig. 8(i), Fig. 8(iii).

Head plate to be of 5mm ALUMINIUM ALLOY or 3mm STEEL 25x3mm FMS strip to be welded to main hoop, top windscreen bar, centre roof bar and side roof bar. Ten of 50x50x3mm MS tags acceptable.

Plate to be mounted, from above, with 10 x 8mm dia. High tensile bolts, 3 each side, 2 front, 2 rear. Heads of bolts to be downwards and tack welded.

ALTERNATIVELY

A head plate minimum 3mm steel must extend from rear roll bar to top windscreen bar and from driver's side outer roof bar to centre roof bar.

This plate must be securely welded to these bars with intermittent welding procedure.

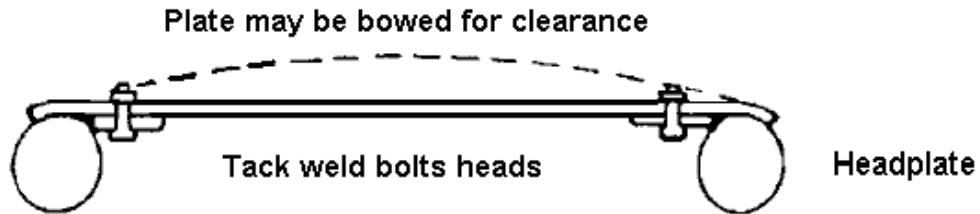

Fig. 8(i)

Helmet clearance between roll cage roof/hoop bars for existing vehicles may be gained by raising head plate as per drawing below, to obtain 50mm clearance. Fig. 8(ii)

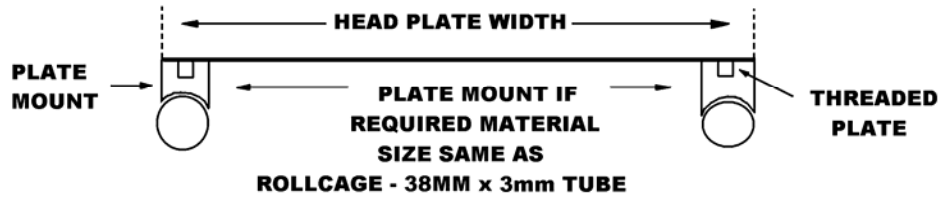

Fig. 8(ii)

Mounting procedure for raising the head plate on existing cars only. 10 stubs 38mm x 3mm tube – stub length is determined by height required to gain 50mm clearance. Fig. 8(ii)

Stubs to be end capped and threaded for mounting purposes.

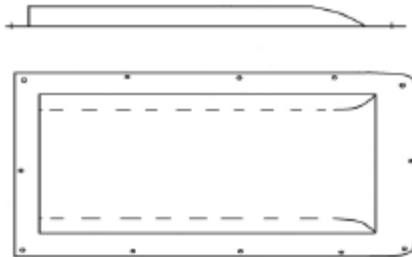

Fig. 8(iii)

25. WINDOW MESH

A mesh screen must be securely fitted to roll cage in front of the driver. With the exception of the front windscreen area, no other window apertures are to be covered with any material.

A mesh screen must be securely fitted to roll cage in front of the driver.

Maximum mesh size 50mm x 50mm, minimum gauge 3mm. Mesh screen to cover entire area from "A" pillar bar to centre bar and from dash to roof bar.

The windscreen mesh must be welded, or clamped with metal clamps to the roll cage "A" pillar and centre windscreen bar. Minimum of four clamps to be used.

26. BALLAST

Ballast must be attached to either roll cage or chassis below door height.

If attached to chassis, must be attached directly to chassis by utilizing half inch high tensile bolts and Nyloc nuts. Bolts going through chassis rail must use sleeve inserts.

If attached to roll cage tubing, correct mounting brackets to be used, e.g. AFCCO.

Ballast should be no greater than 610mm long x 100mm wide x 50mm high.

Each piece of ballast to be painted white with registered car number (for identification).

If ballast is dislodged from a race car during an event, penalties can apply.

Ballast up to 305mm in length requires a minimum of one mounting bolt.

Ballast up to 610mm in length requires a minimum of two mounting bolts.

**Limit of four pieces of ballast per car.
Total weight of ballast to be no greater than 40kg.**

27. BUMPER BARS

Cars must be fitted with pipe bumpers front and rear. They are to be manufactured from CHS maximum 38mm x 3mm.

Bumpers are to remain hollow.

Corners and ends of bumpers to be radius formed 100mm minimum.

FRONT bumper return, 300mm maximum, minimum 100mm.

REAR only: Returns of rear bumper may be extended as a skid rail against the inside of body between bumper and wheel arch, and then extend inward to the chassis rails.

Bumper mountings to be of maximum 38mm x 2.5mm CHS, 40x40x3mm RHS or 50x25x3mm only, gussets are not to be used.

Maximum of four bumper to chassis mounting points for each bumper bar.

The rear of the bumper bar facing the chassis must be 100mm minimum from the chassis rail. Fig. 9(i)

Front & Rear bumper to be securely mounted in original position but must be inside of original plastic bumper panel or moulded replica panels. Front Bumper bar maximum overall width to be no wider than 1960mm. Fig. 9(ii)

Recommend replica panels, be attached with a minimum of four 40mmx 5mm alloy washers and rolled head bolts.

Bumper mounts and supports to be measured from the rear edge of the bumper.

Returns of front bumpers must be extended into the stay bars using 25x25x3mm RHS or 25mm x 3mm CHS. Fig. 9 (i)

Corner plates on top edge of front and rear bumper bar as head/tail light plates not permitted. Override bars are an option to reduce panel damage.

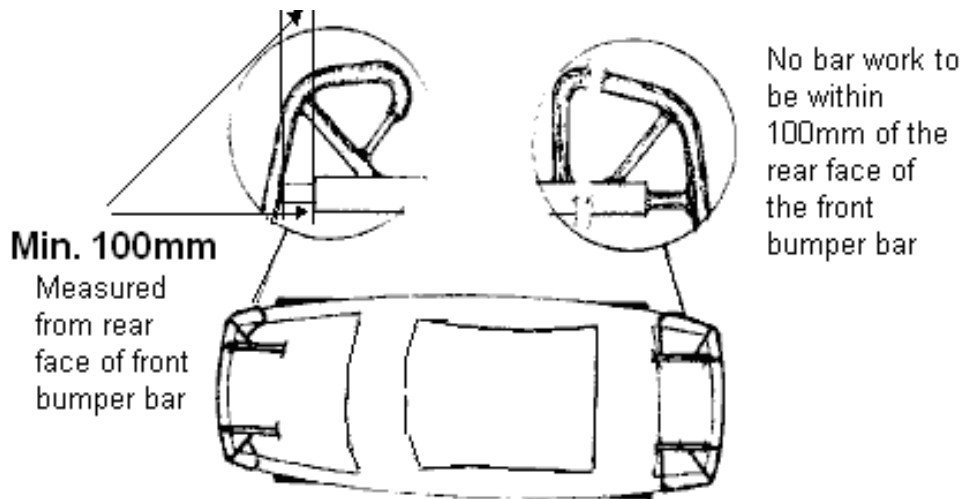

Fig. 9(i)

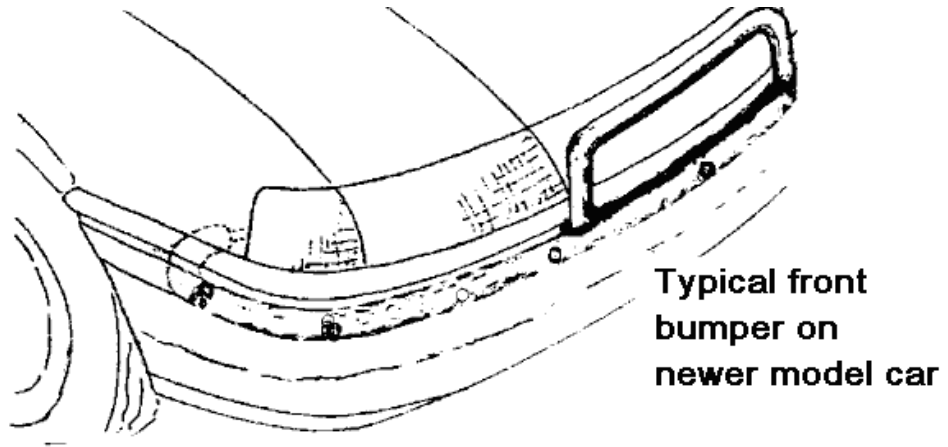

Fig. 9(ii)

28. OVER RIDE BAR

Constructed of maximum 25mm x 3mm CHS, maximum 600mm long, maximum 150mm high and mounted centrally on TOP of bumper. i.e. it may have a centre support.

Brace bars are not to be used. Fig. 9(iii).

The over ride bar is allowed to be exposed through the plastic bumper cover.

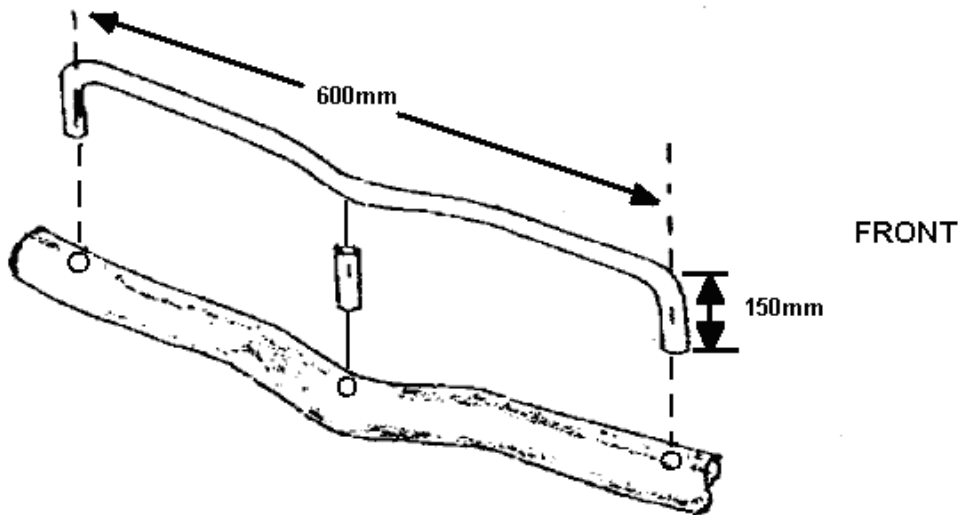

Fig. 9(iii)

29. TOWING ATTACHMENTS

Super Sedan towing attachments will be via the override bars or a hole cut in the panel under the bumper, to allow the bumper to be used to pick up the vehicle.

30. RUB RAILS

Rub rails are an optional fit and take the form of a mild steel rubbing strip between wheel arches 25x25X3mm RHS or alternately a nylon (urethane, nolathane) rubbing strip 50mm x 12mm thick.

It must be securely mounted against body, at a minimum of four points.

Bolts must be minimum 8mm coach head (cuphead) bolts and be bolted horizontally to bar work. Bolts at each end must be no more than 50mm from the end of rub rail.

Inner mounting bar, **minimum** 25 x 25 x 3mm, is to be returned to the chassis or roll cage at each end.

Rubbing rail ends to be closed and taper to 45 degrees as not to become a 'spear'. Fig. 10

Rub strips not to be used on quarter panel behind wheel.

Fig. 10

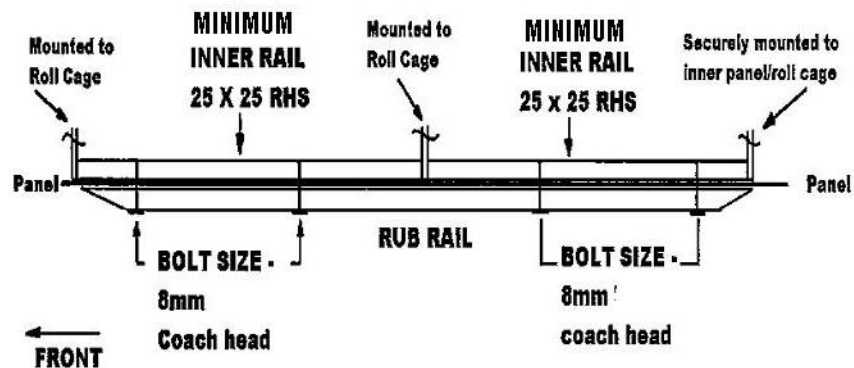

31. FUEL TANK PROTECTION

Bar work must be constructed of minimum 38mm x 3mm CHS or 40x40x3mm RHS and be 25mm clear all around tank and filter, projecting a line from the rear wheel centre to the bar.

Bar is to prevent side entry to tank by nose of another vehicle.

Fuel tank protection bars must have radius formed corners as per diagram. Fig.11. No straight side pipes for jacking to extend.

Protector must be 25mm lower than an underslung tank and mounted as per Fig. 11.

(Brace bars to tank protector do not constitute bumper mounts.)

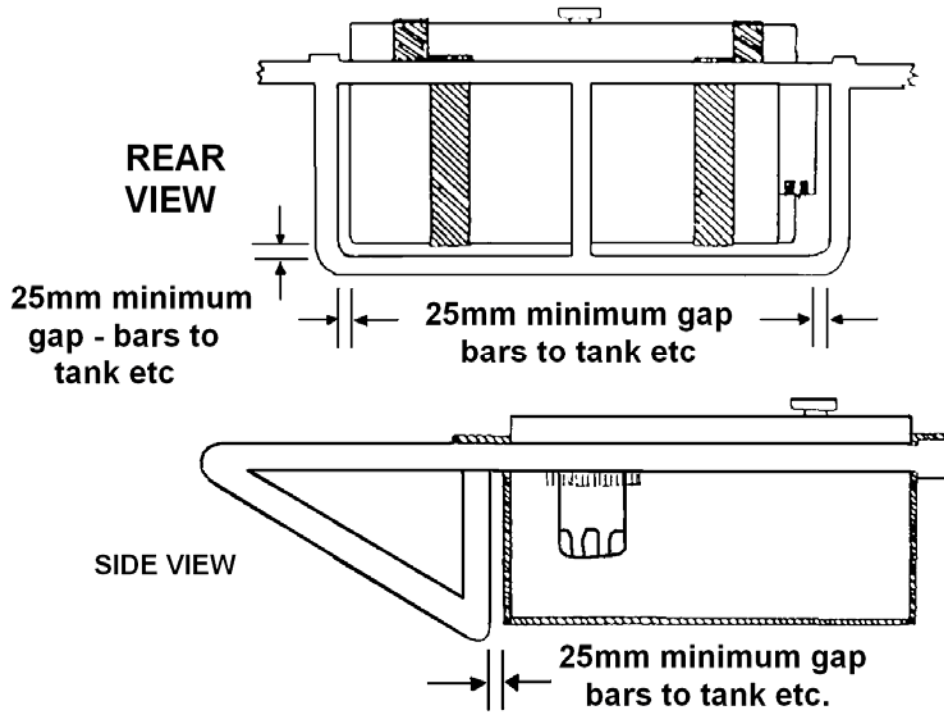

Fig. 11

32. WHEELBASE:

Applies to standard OEM Bodied cars, which may use a nominated variable wheelbase.

Not applicable for short track bodied cars.

Minimum 2540mm, this figure is recorded in the logbook at the time of daylight inspection for registration. Cars with less than OEM of 2540mm may reduce the wheelbase by maximum 1%.

Any increase or decrease in wheelbase is to be split, moving front and rear axle equal distances, e.g. Decrease wheelbase 100mm, front axle moves backward 50mm and rear axle moves forward 50mm.

33. SUSPENSION:

Beam axles are not permitted on the front of the car.

Lower control arms of front suspension shall not cross the centreline of the car.

Front mountings of forward facing rear trailing arms and leaf springs are to be boxed in on top/front on the right hand side to protect the driver.

5th Arm: Adequate side support must be used on 5th Arm to alleviate sideways movement of arm. Bar by seat to protect driver from 5th arm if diff is dislodged; may be tube or substantial flat section. Fig. 12(i) & 12(ii). Minimum 40x5mm FMS. Arm and Coil unit are to be behind firewall.

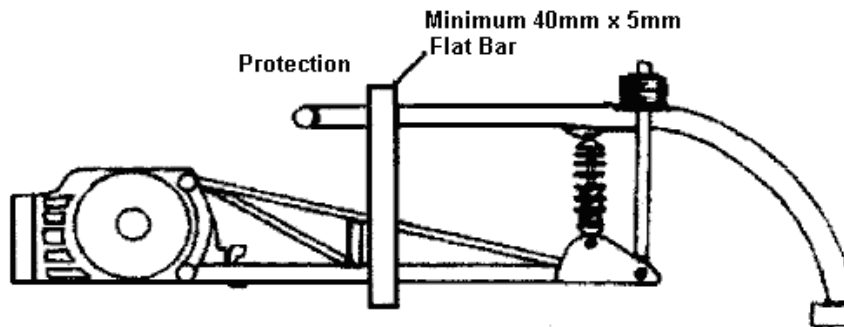

Fig. 12(i)

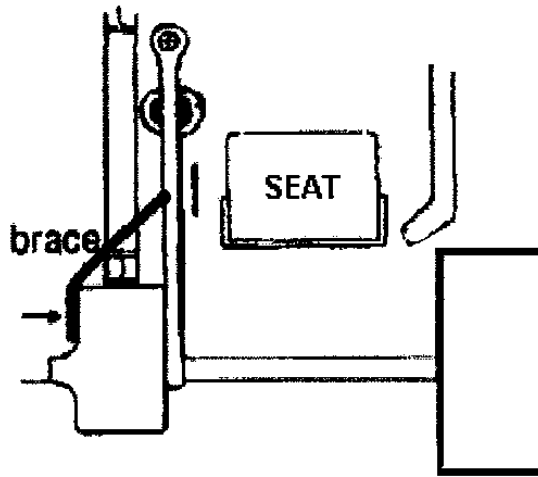

Fig. 12(ii)

Front suspension must be mounted to the chassis or associated bar work, not to the engine.

34. PANHARD BAR

Adjustable panhard bars are permitted provided that they are adjusted manually. eg. With spanners.

NO cockpit adjustments are allowed except for brake bias and brake shut off valve.

NO electronic or hydraulic adjustments allowed.

35. SHOCK ABSORBERS

Externally adjustable shock absorbers permitted. They must be of a type where no adjustment can be carried out from cabin or from the driver's seat. The adjustment of shock absorbers is not permitted once car is formed up on the dummy grid for OH&S reasons.

**** External canister type shock absorbers are not permitted. ****

36. STEERING

Steering components must be in a sound condition. Steering joints to be split pinned as required.

Wire spoke or wood rim steering wheels not permitted.

Steering column must be securely mounted to the roll cage dash bar.

Hub of steering wheel must be padded with dense resilient foam and covered.

To reduce thumb and wrist injuries, the use of "PAW SAVER" type disc steering wheel is HIGHLY RECOMMENDED.

37. BRAKES

Foot operated, hydraulic brakes are to be fitted and be effective at race speeds.

Bias adjustable brake systems are permitted although 'electronic' anti-lock brake systems (ABS) not permitted.

Suspension and brake adjustments are not allowed from the driving compartment, with exception of brake bias and brake shut off valve.

Brakes are to be fitted to a minimum of three (3) wheels. A single brake assembly mounted on a ONE-PIECE (live) rear axle is considered to be brakes fitted to two wheels.

Carbon fibre/titanium brakes and components not allowed.

38. WHEELS

Maximum width of wheel is 12in (305mm) including bead lock attachment. Fig. 13

Wheels must be in good condition and free from cracks.

Dual bolt pattern drillings only permitted on Wide 5 style wheels.

Balance weights to be securely fastened or taped.

Rim edges to be rolled or rounded off if rim protrudes past the tyre side wall.

Removable wheel covers are allowed.

Wire wheels and/or dual wheels not permitted.

Wheels may be reinforced provided they meet with the approval of the State Technical Committee or the Chief Scrutineer.

Street legal after market alloy wheels are permitted. They must be attached with the nuts and washers manufactured for that specific wheel.

Wheels using centre-lock retainer nut must also use an approved locking device to prevent nut from being spun off. Forward rotation of the wheel must tighten the nut.

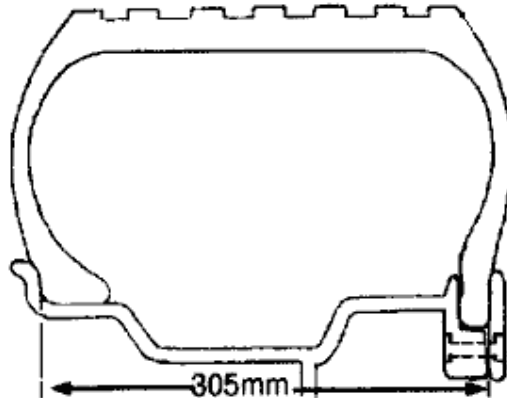

Fig. 13

Steel centre wheels:

Heavy Duty "Off Road" type centres preferred to flat plate.

Wheel centre hole is to be chamfered.

Stud holes must be chamfered to suit the nut used, and be chamfered on inner edge to relieve guillotine action on studs.

Right hand front wheel, if of flat steel plate, is to be of not less than 10mm thickness; if dished centre, absolute minimum thickness 5mm.

39. TYRES

Tyres may protrude maximum 100mm outside of body waist line. This is measured from the body waist line, not the outer edge of the rub rail where fitted.

Tyres must be in good condition.

Any type of lubrication (grease or oil etc.), is not permitted on tyre walls.

40. ENGINE

Any car as originally released for the road with a wheelbase over 2440mm, may be built to run with a 6 cylinder or V8 or V12 engine. Any car with a wheelbase less than 2440mm must apply to the SSA Inc Technical Committee for prior approval to be constructed with a V8, V12 or six cylinder engine as its power plant.

If a car is produced with rear engine it must remain rear engine. If a car comes out with front engine it can be front engine only but may convert FWD to RWD and also convert E-W to N-S.

Single register recording equipment including instruments that supply on-board only engine rpm, rev limiter, oil pressure, fuel pressure, coolant temperature and lambda information are allowed, provided no actuators are used during race meetings.

Multiple register recording data logging devices including programmable electronic control units (ECU) are not allowed on V8 and V12 engines but may be used with 4cyl and 6cyl applications.

a. ENGINE BLOCK

All engines must have a number stamped on the block.
Eg: 3 engines 3 different engine numbers. Can even have letters or car number.

No titanium cranks or con rods allowed.

Block must be based on a passenger car engine only.
Engine may be of Rotary (Wankel) OR of a reciprocating type in any mass produced configuration.

Maximum capacity after all modifications 367cu.in absolute.

Aluminium V8 and aftermarket V6 Aluminium alloy engine blocks are not permitted. GEN III V8 blocks not permitted.

Cast iron Heavy Duty engine block permitted.

292 Chev 6 Cylinder not accepted as they are only in "Commercial" vehicles.

b. CYLINDER HEADS

Only two valves per cylinder permitted in V8 or V12 engines.

Splayed valve cylinder heads not permitted unless OEM.

Overhead cam cylinder heads are not permitted on V8 or V12 engines.

Canted valve cylinder heads are not permitted, except on Ford as per OEM standard configuration.

c. CRANKSHAFTS

Crankshafts are permitted to be lightened and balanced.

The use of titanium cranks not permitted.

d. INDUCTION

Engines of eight or more cylinders, or MORE than two rotors are restricted to carburettor/s and a maximum of four normally aspirated venturi only.

Twin rotor Rotary engines and engines of less than eight cylinders may use carburettor/s or fuel injection and may also use forced induction.

e. IGNITION

Ignition systems must not contain or actuate any traction control function.

The SSA reserves the right to download information via computer.

Kill switch to be clearly marked for method of operation e.g. DOWN/OFF

f. FUEL

Petroleum fuel or methanol may be used. Maximum specific gravity of fuel:- 0.820 methanol; 0.780 Petrol. Gaseous fuels not permitted.

Petroleum fuels not to be used in fuel injection systems unless using original equipment (OEM) on the engine.

4 or 6cyl or Rotary engines fitted to super sedans using ECU are allowed to use methanol fuel.

The introduction into the combustion chamber/s of nitrous fuels and/or additives, either in solid, liquid or gaseous form, (e.g. nitrous oxide) by any means whatsoever, is expressly forbidden.

The use of upper Cylinder lubricant via carburettor or vacuum system is illegal except when using OEM equipment. Any vehicle found with these types of systems will be deemed illegal.

g. EXHAUST SYSTEM

Exhausts must comply with local noise level requirements. Recommended 95 dB.A.

All exhaust gases to be directed away from all drivers, fuel tanks and tyres.

Internally ducted exhaust system may vent through the body, maximum 100mm above chassis.

Exhaust system to have not more than two outlet pipes, and not protrude beyond body line. Fig.14

Pipes and mufflers must be securely attached to the vehicle.

Any car exhausting excessive unburnt Methanol fumes while on dummy grid, or being formed up on the track, may be excluded as this constitutes a health hazard.

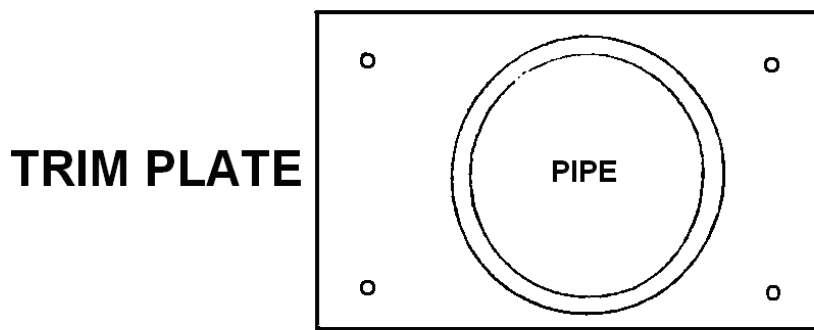

Panel flexes but pipe does not protrude

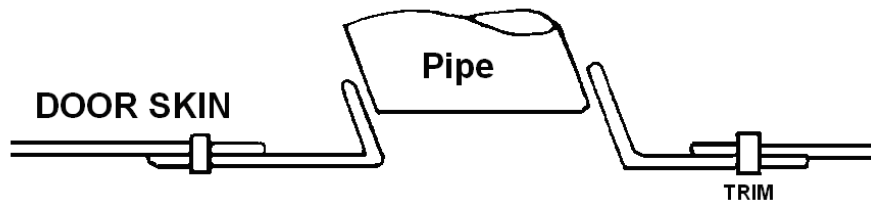

Fig. 14

h. COOLING SYSTEM:

Cooling system may be modified.

Cooling system to have a manual pressure relief tap/cap fitted. Lever vent type may be used.

Tap to be fitted with a hose to direct steam to the ground.

All radiator hoses to be of fabric reinforced material, plain moulded rubber hoses not permitted.

Radiators may be mounted inside cabin provided that they are mounted as low as possible and suitably isolated from the driver. The upper half of rear window opening **MUST NOT** be obscured by rear radiator.

Radiator ducting shroud, if used, to be a maximum of 600mm forward of the radiator and must not obstruct more than half the rear window height. Cabin mounted radiators must have **BOTH** tanks covered to protect driver in event of a cap or tank blowing.

Pipes are to be securely mounted within the roll cage.

All internal pipes are to be ducted or lagged with suitable material.

Hoses to be as short as possible and may enter from front.

Exposed hoses or joints not permitted in cabin area.

Cabin mounted fans to have shroud or suitable guard.

Cabin mounted water pumps must be lagged or covered by a suitable guard.

All header tanks, hoses and caps in cabin area to be covered as per radiator tanks and hoses to prevent hot water burning driver or drivers of other cars. Must be mounted below half window height.

ENGINE SEALING IS COMPULSORY

All engines are to be sealed to enter events and details to be entered in page 8 of vehicle's log book.

Engine Identification Seals for Super Sedan Class are Yellow.

Engine Seals will be placed – 1 x Sump and Timing Cover.

i. ENGINE POSITION

Engine including cylinder heads and rocker covers is to be totally mounted inside the front chassis rails. Fig. 15 (i)

Engine position (SETBACK): Rear face of engine block to be not less than three-quarters (3/4) of the nominated wheelbase from the centreline of the rear axle. (Fig. 15(ii)) (existing '72-'82 Corvette 62"). 6 cylinder engines 70% of wheel base.

Rocker Covers

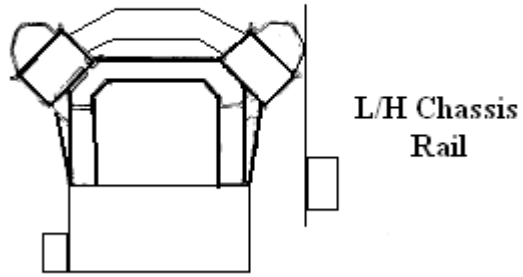

Fig. 15(i)

Existing in-line 6 cylinder has option of 215mm from original position or $\frac{3}{4}$ wheelbase rule.

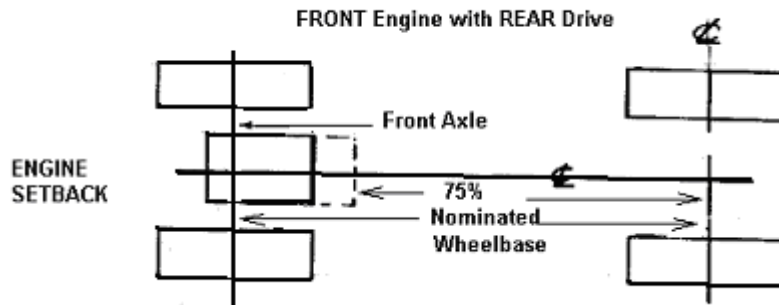

Fig. 15(ii)

TABLE 2:

ENGINE SETBACK (Minimum distance from Rear Axle CENTRELINE) Fig. 15 (ii)

Nom.dW/BASE	75% Wheelbase	Nom.dW/Base	75% Wheelbase
95"	71.25"	2413.0mm	1809.75mm
96"	72.00"	2438.4mm	1828.8mm
97"	72.75"	2463.8mm	1847.85mm
98"	73.50"	2489.2mm	1866.9mm
99"	74.25"	2514.6mm	1885.95mm
100"	75.00"	2540.0mm	1905.0mm
101"	75.75"	2565.0mm	1924.05mm
102"	76.50"	2590.8mm	1943.1mm
103"	77.25"	2616.2mm	1962.15mm
104"	78.00"	2641.6mm	1981.2mm
105"	78.75"	2667.0mm	2000.25mm
106"	79.50"	2692.4mm	2019.3mm
107"	80.25"	2717.8mm	2038.35mm
108"	81.00"	2743.2mm	2057.4mm
109"	81.75"	2768.6mm	2076.45mm
110"	82.50"	2794.0mm	2095.5mm
111"	83.25"	2819.4mm	2120.9mm
112"	84.00"	2844.8mm	2133.6mm

Solely to permit mounting of supercharger/turbo under the permitted 100mm power bulge, approval is given for in-line 6 cylinder users to lay the engine over.

In all other cases, vertical remains vertical etc., spark plugs in Rotary engines remain horizontal and vee engines are to be balanced against a vertical centreline.

VW BEETLE engine and transmission may be transposed.

Rear engine, mid engine and front wheel drive engine positions:-
Rear engine car reverse Table 2

If constructor wishes to use other than original, approval is to be obtained in advance by submitting specific proposal to SSA Inc Technical Committee. Specific details will remain 'in confidence'.

If resilient engine mountings are used, a wire cable or chain restraint must be fitted.

Oil reservoirs, remote oil filters, coolers etc., must be: securely mounted, isolated from driver, and not impair vision through cabin area.

All connecting hoses, couplings etc., are to be correct class of fittings for the purpose.

Leak proof caps to be fitted wherever oil caps are used.
Return springs must be fitted to each butterfly shaft (inbuilt throttle springs acceptable), and one spring to accelerator pedal linkage.

Protective wire gauze or air cleaner is to be fitted over air intake to prevent entry of foreign objects to throttle butterfly and also act as a flame trap.

41. TRANSMISSION AND DRIVETRAIN

Any form of Electronic Traction Control systems not permitted.

Gearbox must have a minimum of two forward gears and reverse gear.

Every race car is to be fitted with a clutch so that the engine may be started, and then the vehicle can be put into gear and move off in forward or reverse as required.

For SAFETY 'full floating' rear axle assembly recommended.

SCATTER SHIELD: Front engined cars, not using competition type enclosed clutch or competition bell housing, must fit a scatter shield to cover the upper half of the bell housing and protect the driver's feet and legs. Scatter shield to be a minimum 3mm steel or 6mm alloy, and must be securely mounted.

Tail shaft loops Steel strap minimum. 40mm x 5mm or 6mm chain or 6mm wire rope to be SECURELY fitted around the front and the rear of the tail-shaft within 150mm of universal joints to prevent the tail-shaft and or shafts from dropping in an event of breakage.

Tail shaft and universal joints to be correctly phased and be suitable for the application.

No carbon fibre tail shafts.

REAR AXLE BEARING RETAINING RINGS: If using a rear axle assembly not fitted with floating axles, a new retaining ring must be fitted at replacement of bearing or axle. Ring must be an interference fit with the axle. When in place the retaining ring is to be tack-welded to the axle using MIG or small diameter low hydrogen rod on low amperage.

Failure to observe this procedure will incur a penalty, especially if an axle is dislodged.

WHEEL STUDS: Grade 8, 12mm minimum all vehicles.
Titanium axles not permitted.

42. BATTERY AND ELECTRICAL SYSTEM

Battery must be securely mounted in a box or steel frame secured to the roll cage or bar work.

It is recommended that rubber covering be placed over the battery and the exposed metal of the cable terminals:

- i.) to reduce acid spillage and
- ii.) to reduce chance of arcing if metal contacts battery in an incident.

Suitable grommets must be fitted where battery cable passes through metal firewalls.

At the commencement of a meeting, car must be capable of starting with starter motor.

Switches: Ignition switch and electric fuel pump switch, if fitted, must be grouped together and be clearly marked.

An engine 'KILL' switch, suitably marked, must be fitted in centre of cowl panel.

Electrical switches NOT to be mounted through the floor.

Transponders must be mounted 150mm forward of the front axle centreline on the left hand chassis rail.

43. FUEL TANK AND FUEL SYSTEM:

Use of cooling systems for fuel not permitted.

A fuel cell of up to 72 litres for petrol or 140 litres for methanol must be fitted. The area beneath tank must be open. Pressurised fuel tanks NOT permitted.

Fuel tap is to be marked indicating FUEL and the positions of ON/OFF.

Filler cap to be a positive seal and inside body and behind a firewall.

Levers of cam lock caps to be clipped closed.

Aluminium fuel cells may be used, but must include a bladder.

Fuel cell is to be securely mounted inside the boot area, mounted entirely between the chassis rails behind rear axle centre line. In a suitable metal cradle attached to the chassis or cage bracing, with a minimum clearance of 150mm forward of the lower rear end boot panel and 300mm minimum from the side of the vehicle and isolated from driver by a firewall. In rear engine cars, front mounted tank must be behind the front axle.

Tank vents to be fitted with an anti-spill device.

A flexible fuel line section must be fitted within 75mm of fuel tank and all fuel lines to be securely fixed in position. Barbed fittings of the correct size must be used in conjunction with screw type clamps when connecting flexible fuel line, exception being genuine SAE R6 lines and fittings. Neoprene, reinforced plastic or 'black fuel line' may be used.

The fuel line to the engine must be fitted with a quick action NON-LEAK fuel tap, in working order, securely mounted within easy reach of driver and crash crew, and clearly marked FUEL ON-OFF positions. Return lines to the tank are to be fitted with a 'one way' valve.

Electrical fuel pump must be isolated from the driver by a firewall, be fitted with an independent earth to case, and be switched off by the KILL switch and by an engine monitoring relay.

Fuel lines MUST BE ISOLATED from electrical wiring.

44. GENERAL BODY FITMENT

Body is to be a complete outer shell and a replica/representative of the MODEL being used. It must be fitted so that the centreline of the body coincides with the centreline of the chassis. Fig. 16(i)

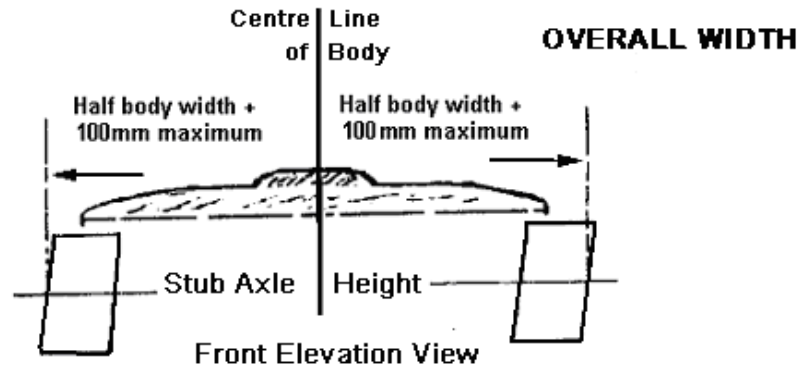

Fig. 16(i)

All Bodywork, including any subsequent repair of race day damage, shall be to a tradesman like standard and must permit the vehicle to be presented in as near to original condition as possible.

Panels to be attached using rivets or bolts. No cable ties or race tape unless race night repairs.

All Super Sedans will comply with approved body measurements. For new models or unusual models; Constructor must provide authentic dimensions of a 'road going' car of that model.

Existing body measurements remain as is and the short track style body measurements in Table 3, 3a and 4 to apply and cars to comply with either body specifications. Tolerance for body measurements is +/- 25 mm overall, with the exception of the front and rear overhangs, which are maximum measurements.

See also Wheelbase section.

Body panels must be complete including rear quarter panels below bumper and the rear panel down to the bumper.

Side body panels must be parallel.

With the exception of the front windscreen area, no other window apertures are to be covered with any material.

BODY - X-RAY VIEW LH SIDE

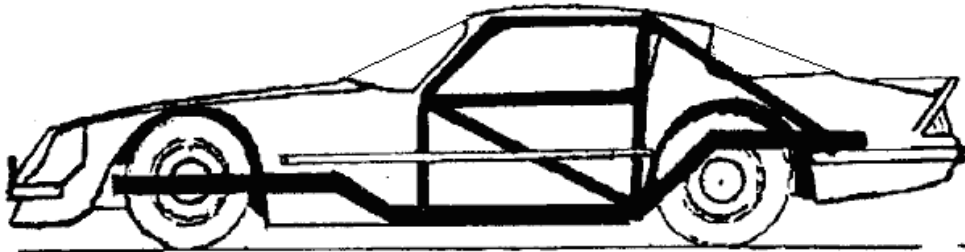

Fig. 16(ii)

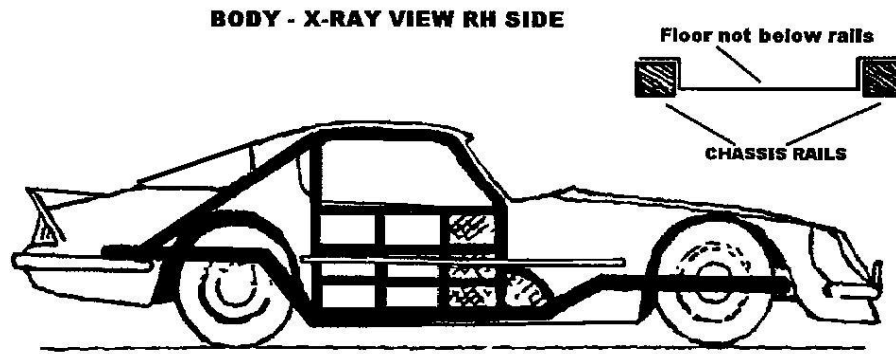

Fig. 16(iii)
See Section 20 Chassis
See Section 21 Rollcage
See Section 44 General Body Fitment

Fitment of body – See Fig. 16(i),16(ii) and 16(iii).

The body is to be fitted in such a manner that it does not appear to raked in any form and that the body runs parallel with the chassis.

No part of the body, including the nose cone is to hang below the chassis rail. The bottom of the nose cone must remain parallel with chassis.

Minimum radius on the top of the rear quarters, front guards, and door panels is to be 20mm.

Body is not to be higher than half the measurement of the chassis rail above the bottom of the chassis rail.

Metal floor (1.6mm) fitted on top of chassis rails, NOT below. Fig.16(iii).

Deflection curve at top and bottom of each side panel relative to the waistline is to be 50mm minimum to 125mm maximum. Fig. 16 (iv)

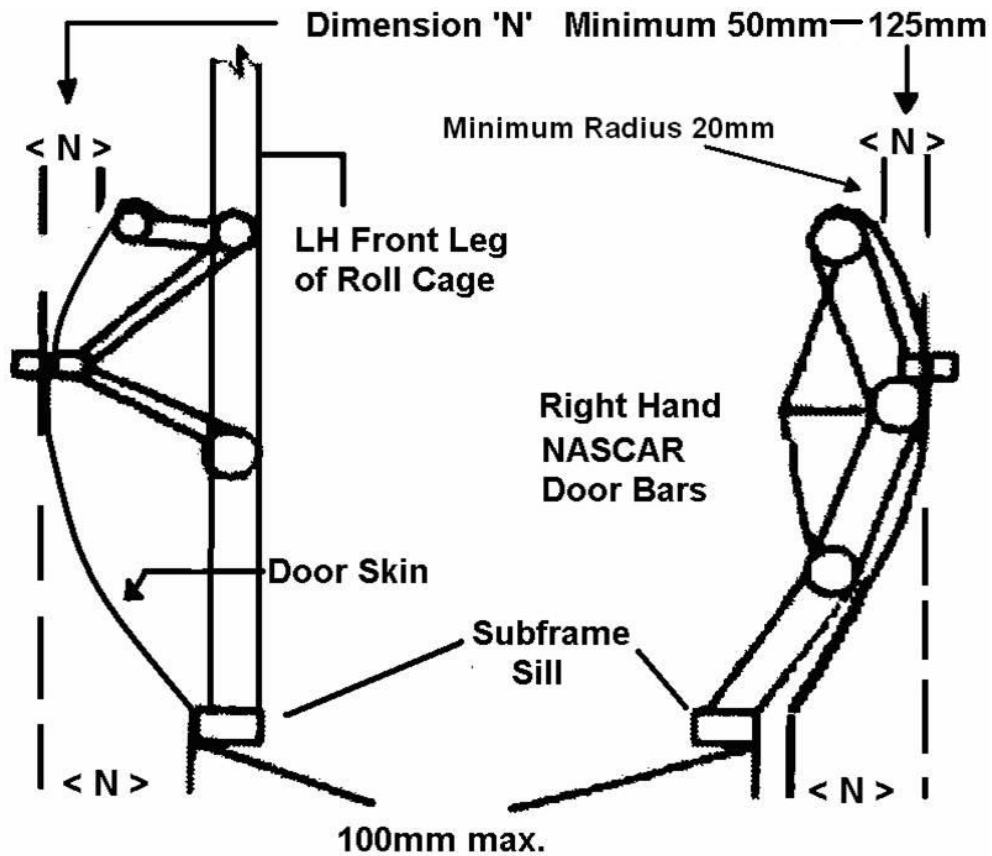

Fig. 16(iv)

45. BONNETS AND BOOT LIDS

Bonnet is to be securely fastened by five bonnet pins to be 12mm minimum to 15mm maximum mild steel or approved equivalent.

Bonnet lock pins 3mm minimum to 6mm maximum. Heavy-duty large reinforcing washers (30mm OD minimum) to be fitted to all bonnet pin holes. Similarly, boot lid to be securely fitted, using pins and large washers as for bonnet.

Boot lid to be of profile and shape to match approved body measurements. Rear interior sheeting may extend only to the front leading edge of the boot lid.

A removable boot lid is to be securely mounted in four points.

Access panel in rear deck panel or boot lid must allow access to fuel tank for scrutineering, 650mm x 300mm minimum. Must be quick release.

Hinged bonnet and boot lids permitted.

Power bulge/s permitted to max 100mm at any point above the original bonnet, measured from a line across both front guards.

Air cleaner may protrude through a flat bonnet to a maximum height of 100mm and/or

A bonnet with scoop will also be measured from flat section of bonnet.

Maximum clearance around filter – 20mm.

46. REAR SPOILERS

Rear spoilers are an optional fitting on all bodies. Spoiler is to be a maximum of 180mm high. A maximum of two supports permitted between the sides of spoiler.

Side support/s of rear spoiler must taper to zero not more than 300mm forward from the base of the spoiler. (Measurement taken from the rear top edge of the boot) Fig. 17(i). Side support is not to be above horizontal.

Spoiler shall not overhang past rear bumper including corners. Fig. 17(i)

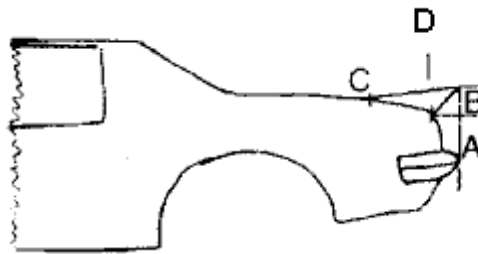

- A. Not to extend beyond original bumper line.**
- B. Maximum 180mm high.**
- B to C. Must taper to zero max. 300mm.**
- D. Blade length 400mm.**

Fig. 17(i)

Spoiler Blade length - maximum 400mm.

"Hungry Boards" are not permitted.

Partial folds on top edge of side supports of rear spoiler for strengthening are not permitted.

Spoiler shall be no wider than the body is at that point. (e.g. if body at waist line on rear quarter is 1650mm wide then maximum width of spoiler above that point is 1650mm also) Fig 17 (ii).

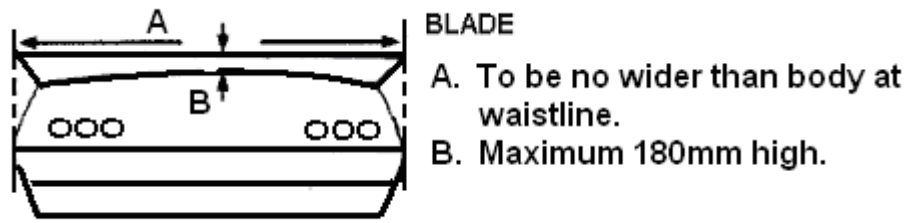

Fig. 17(ii)

47. V8 SUPERCAR WINGS

V8 Super car rear wings are allowed on Falcon, Commodores, and VX/VY Monaros only.

End plates must be a replica/representative of V8 Supercar end plates.

V8 SUPER CAR WING MOUNTING SPECIFICATIONS: REAR VIEW



CENTRE MOUNT - GROUP A REAR WING:

REAR VIEW

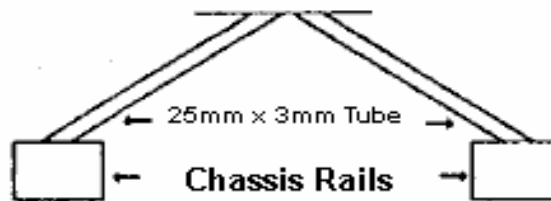

The blade must be the profile of the original v8 Super Car Wing

The wing will be mounted on the rear of the car, no further back than the rear bumper bar. The blade is not to be wider than the waistline of the body of the car, where fitted, must not overhang on corners.

V8 Supercar rear wing must not overhang past the body panels and the rear bumper in any direction.

The wing will be attached with a minimum of two 6mm bolts per leg, making at least four bolts with substantial washers, at least 25mm diameter. These bolts will attach through the boot lid or rear decking to 3mm plate. This 3mm flat plate is to be attached to the chassis using 25x25mm mild steel. The 25mm tube will be welded to the rear chassis rails.

The V8 Super Car rear wing fitted to Commodores and Falcons must be no higher than 330mm above the boot lid, at the highest point. When fitted to a Monaro, the blade can be no higher than 180mm above the boot lid.

A front air dam may be fitted.
Other aerodynamic aids not permitted.

48. FLARED WHEEL ARCHES

The front and rear wheel arches to be a continuous radius. Fig. 18(i)

Body may be flared on each wheel arch. Wheel arch flare must resemble an eyebrow around the tyre and follow the contour of the wheel arch aperture and taper in within 100mm of the opening. Fig. 18(ii)

Flare edges are not to be reinforced and are not to detract from the original appearance of the model being used.

Flares are to be of body material.

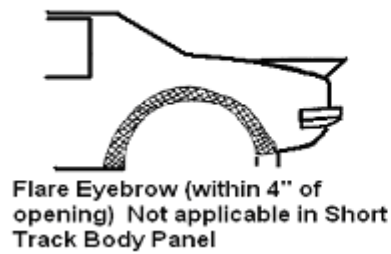

Fig. 18(i)

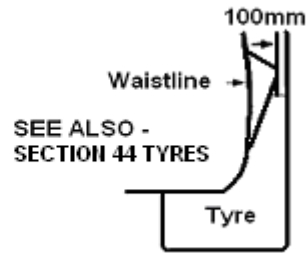

Fig. 18(ii)

49. PRESENTATION AND SIGNWRITING

All paintwork, sign writing and numbers is to be neat, attractive and of a professional standard.

All vehicles must carry the correct identification number as issued by their club. This number may be displayed on each side of car and on the roof.

Identification number is to be visible from front of car. Club prefix, is required, to precede number.

An I.D. number visible from the rear of the car (this will aid in line up with one way communicators).

The name of the driver will appear on the roof over RH door or on visor strip, in letters of a minimum of 75mm high.

The fitting of roof number plates is mandatory unless supplementary regulations state otherwise (transponders). If required, it shall be a metal plate, 30cm square with a 5 cm right angle fold at the bottom, where 2 holes, at 20cm centres shall be drilled to take 6mm bolts.

The number on the plate shall be painted using a black background & white number/s. Number to be minimum 250mm high in block font.

Headlight and tail light apertures to be covered with body material only. They may be highlighted by decal or silhouetted to help identify make and model.

50. INTERIORS AND FIREWALL

Driver must be protected and isolated from mechanical, fuel, electrical and exhaust components by metal firewalls, minimum 1mm thick.

Rear Vision Mirrors are not permitted.

51. ADDITIONAL REQUIREMENTS FOR OEM BODIED CARS.

All body measurements must be OEM original measurements. A nominated wheelbase as per wheelbase (Section 32) is permitted.

Any car as originally released for the road and with a wheelbase over 2440mm, may be built to run with a 6 cylinder, V8 or V12 engine.

Any car with a wheelbase under 2440mm must apply to the Technical Committee for prior approval to be constructed as per new specifications. With a V8, V12, or 6 cylinder as an engine swap.

52. ADDITIONAL REQUIRMENTS FOR 5 STAR SHORT TRACK BODIES.

Original Metal Panels: This refers to all body measurements as per specifications in Table 3, 3a and Table 4

Original metal panels may be replaced with panels as per short track body specifications.

No laying back or flattening down of the nose cone. Eg: If using a MD3 nose cone, it must be of stock appearance and must NOT be wedged in any form and must have a CONVEX SHAPE when viewed from side on and resemble the cars in the rear section of the specification book.

Decals indicating make and/or model are to be fixed to the vehicle in prominent positions.

Turret/Roof to be SSA approved.

Aluminium- Bullet Australia
Rocket Australia

Fibreglass-

Five Star
Five Star replica
OEM composite copy

53. BODY SPECIFICATIONS AND MEASUREMENTS FOR 5 STAR SHORT TRACK BODIES

THESE MEASUREMENTS ARE MAXIMUM.

- B. Front overhang
- C. Side window opening etc
- G. Rear overhang
- I. Mudguard Height.
- J. Door Height

SHORT TRACK BODY

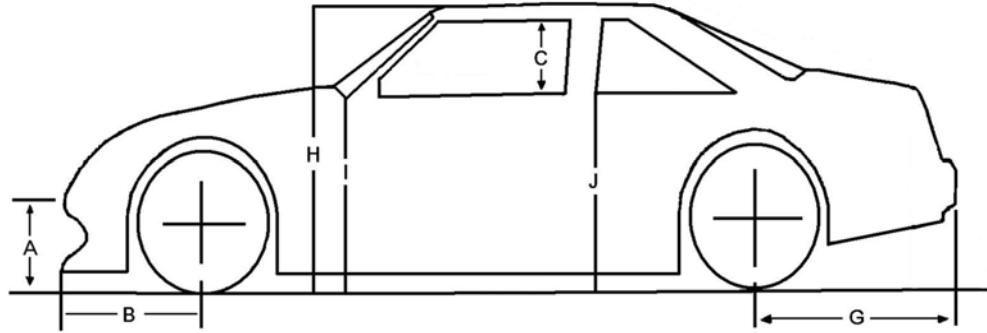

**TABLE 3
GUIDELINE DIMENSIONS IN mm BASED ON 2670 WHEELBASE**

	1997/04 GRAND PRIX	1996 MONTE CARLO	1996 DODGE AVENGER	1996 FORD T'BIRD	1995 GRAND PRIX	1996 CHEVY CAMARO	1996 PONTIAC F'BIRD	1992 CHEVY CAMARO	1990 PONTIAC F'BIRD
A	440	410	430	460	450	430	415	495	510
B	1090	1145	1065	1055	1090	1180	1185		1090
C	385	385	380	380	380	370	370	375	375
G	1320	1310	1245	1270	1220	1245	1300		
H	1220	1220	1220	1220	1220	1220	1220	1220	1220
I	825	825	825	825	825	825	825	850	850
J	830	830	835	850		845	845	850	850

Dimensions A & H are included only as an aid to mount the body.

- A. Nose height measured from ground to top of bumper (generic nose cone permitted)
- H. Roof/Turret Height

TABLE 3a

	EA-EF FALCON	VN-VS C'DORE	VT	AU	RX7
B	980	980	1050	980	1005
C	445	380	405	385	
G	1300	1300	1300	1300	1300
H	1270	1270	1280	1250	1170
I	865	825	700	720	700
J	865	825	700	760	700

Cars may be built to the dimensions in Table 3 & 3a or may use maximum front overhang (B) 1200mm or maximum rear overhang (G) 1300mm.

The easiest way to determine the furthest point of the car is:

If you drive the car up to a wall at 90 degrees and measure from the point that touches the wall first to the centre line of the axle. The same applies to the rear of the car.

54. SHORT TRACK BODIES 2004 ONWARDS

All Measurements for Short Track Bodies Based on 101" Wheel Base using regulations for 5 Star bodies in the USA as a guide only.

As per the 5 Star Specifications (A-B-C, Approved Body Configuration), the front overhang is (B) measured from the centerline of the front hub to the centre point of the front nose (Furtherest point)

Rear over hang is also measured (G) from the centerline of the rear axle to the rear bumper (Furtherest point).

Roof position is for a guide only measured from the rear centre of the roof to the baseline of the spoiler.

TABLE 4

B	Front overhang	Maximum 1200mm
C	Window opening	Maximum 380mm
G	Rear overhang	Maximum 1300mm
I	Door height	Maximum 825mm